

Instruction Manual

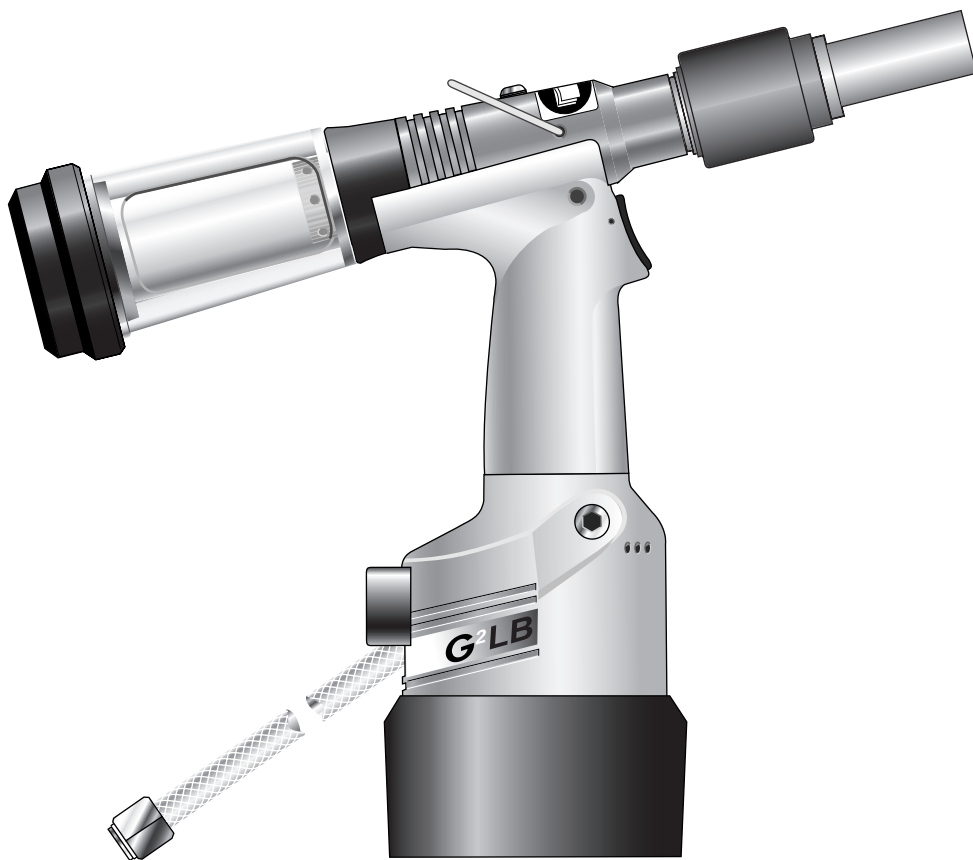

Genesis[®] G2LB

Hydro-Pneumatic Power Tool

Contents

Safety Rules	4
Specifications	
Tool Specification	5
Tool Dimensions	5
Intent of Use	
Part Numbering	6
Putting into Service	
Air Supply	7
Operating Procedure	7
Nose Assemblies	
Avdelok® and Maxlok® Nose Assemblies	8
Fitting Instructions Avdelok®	9
Servicing Instructions	9
Fitting Instructions Maxlok®	10
Servicing Instructions	10
Accessories	
Stem Deflector	11
Extension	11
Servicing the Tool	
Daily / Weekly	12
Moly Lithium Grease EP 3753 Safety Data	12
MolyKote® 55m and MolyKote® 111 Safety Data	13
Annually	14
Service Kit	14
Head Assembly	14-15
Pneumatic Piston Assembly	15
Valve Spool Assembly	15
Trigger	15
General Assembly of Base Tool	
General Assembly and Parts List	16-17
Priming	
Oil Details	18
Hyspin® VG 32 Safety Data	18
Priming Kit	18
Priming Procedure	19
Fault Diagnosis	
Symptom, Possible Cause and Remedy	20

LIMITED WARRANTY

Avdel makes the limited warranty that its products will be free of defects in workmanship and materials which occur under normal operating conditions. This Limited Warranty is contingent upon: (1) the product being installed, maintained and operated in accordance with product literature and instructions, and (2) confirmation by Avdel of such defect, upon inspection and testing. Avdel makes the foregoing limited warranty for a period of twelve (12) months following Avdel's delivery of the product to the direct purchaser from Avdel. In the event of any breach of the foregoing warranty, the sole remedy shall be to return the defective Goods for replacement or refund for the purchase price at Avdel's option. THE FOREGOING EXPRESS LIMITED WARRANTY AND REMEDY ARE EXCLUSIVE AND ARE IN LIEU OF ALL OTHER WARRANTIES AND REMEDIES. ANY IMPLIED WARRANTY AS TO QUALITY, FITNESS FOR PURPOSE, OR MERCHANTABILITY ARE HEREBY SPECIFICALLY DISCLAIMED AND EXCLUDED BY AVDEL.

Avdel UK Limited policy is one of continuous product development and improvement and we reserve the right to change the specification of any product without prior notice.

Safety Rules

This instruction manual must be read with particular attention to the following safety rules, by any person installing, operating, or servicing this tool.

- 1 Do not use outside the design intent.
- 2 Do not use equipment with this tool/machine other than that recommended and supplied by Avdel UK Limited.
- 3 Any modification undertaken by the customer to the tool/machine, nose assemblies, accessories or any equipment supplied by Avdel UK Limited or their representatives, shall be the customer's entire responsibility. Avdel UK Limited will be pleased to advise upon any proposed modification.
- 4 The tool/machine must be maintained in a safe working condition at all times and examined at regular intervals for damage and function by trained competent personnel. Any dismantling procedure shall be undertaken only by personnel trained in Avdel UK Limited procedures. Do not dismantle this tool/machine without prior reference to the maintenance instructions. Please contact Avdel UK Limited with your training requirements.
- 5 The tool/machine shall at all times be operated in accordance with relevant Health and Safety legislation. In the U.K. the "Health and Safety at Work etc. Act 1974" applies. Any question regarding the correct operation of the tool/machine and operator safety should be directed to Avdel UK Limited.
- 6 The precautions to be observed when using this tool/machine must be explained by the customer to all operators.
- 7 Always disconnect the airline from the tool/machine inlet before attempting to adjust, fit or remove a nose assembly.
- 8 Do not operate a tool/machine that is directed towards any person(s) or the operator.
- 9 Always adopt a firm footing or a stable position before operating the tool/machine.
- 10 Ensure that vent holes do not become blocked or covered.
- 11 The operating pressure shall not exceed 7 bar.
- 12 Do not operate the tool if it is not fitted with a complete nose assembly unless specifically instructed otherwise.
- 13 Care shall be taken to ensure that spent stems are not allowed to create a hazard.
- 14 If the tool is fitted with a stem collector, it must be emptied when half full.
- 15 If the tool is fitted with a stem deflector, it should be rotated until the aperture is facing way from the operator and other person(s) working in the vicinity.
- 16 When using the tool, the wearing of safety glasses is required both by the operator and others in the vicinity to protect against fastener ejection, should a fastener be placed 'in air'. We recommend wearing gloves if there are sharp edges or corners on the application.
- 17 Take care to avoid entanglement of loose clothes, ties, long hair, cleaning rags etc. in the moving parts of the tool which should be kept dry and clean for best possible grip.
- 18 When carrying the tool from place to place keep hands away from the trigger/lever to avoid inadvertent start up.
- 19 Excessive contact with hydraulic fluid oil should be avoided. To minimize the possibility of rashes, care should be taken to wash thoroughly.
- 20 C.O.S.H.H. data for all hydraulic oils and lubricants is available on request from your tool supplier.

Specifications

Tool Specification

Air Pressure	Minimum - Maximum	5-7 bar (72.5 - 101.5 psi)
Free Air Volume Required	@ 5.5 bar	2.1 litres
Stroke	Minimum	13mm
Pull Force	@ 5.5 bar	12.47 KN
Cycle time	Approximately	1 second
Noise Level		75 dB(A)
Weight	Without nose equipment	1.35 kg
Vibration	Less than	2.5 m/s ² (8.2 ft/s ²)

Tool Dimensions

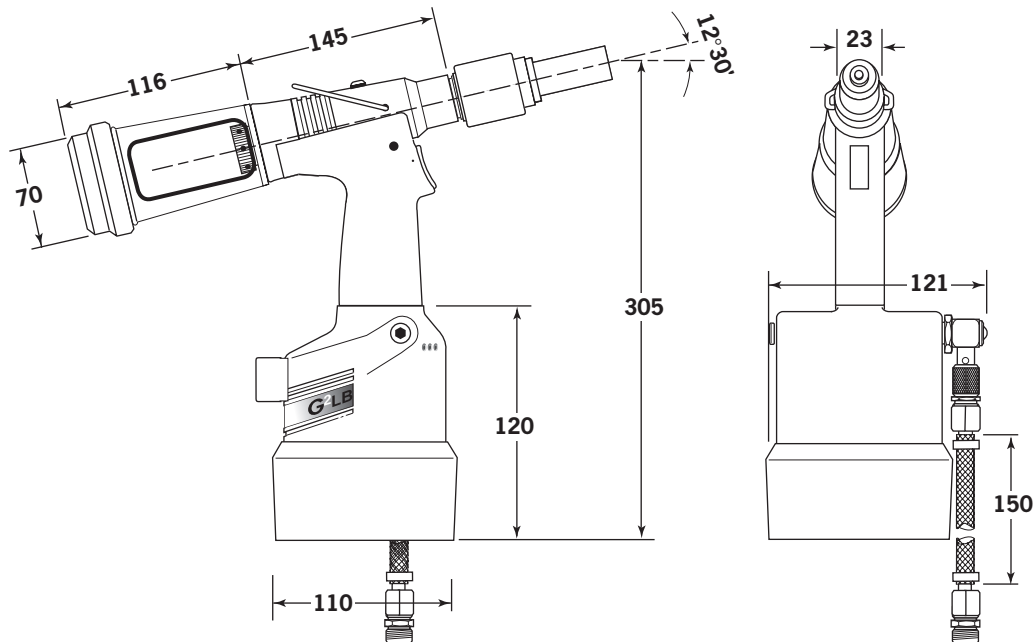

Dimensions in millimetres.

Intent of Use

G2LB is a hydro-pneumatic tool designed to place Avdel Avdelok®/Maxlok® fasteners at high speed making it ideal for batch or flow-line assembly in a wide variety of applications throughout all industries.

A complete tool is made up of two separate elements. See diagram below.

NOSE EQUIPMENT MUST BE FITTED AS DESCRIBED ON PAGES 8-9-10.

Part Numbering

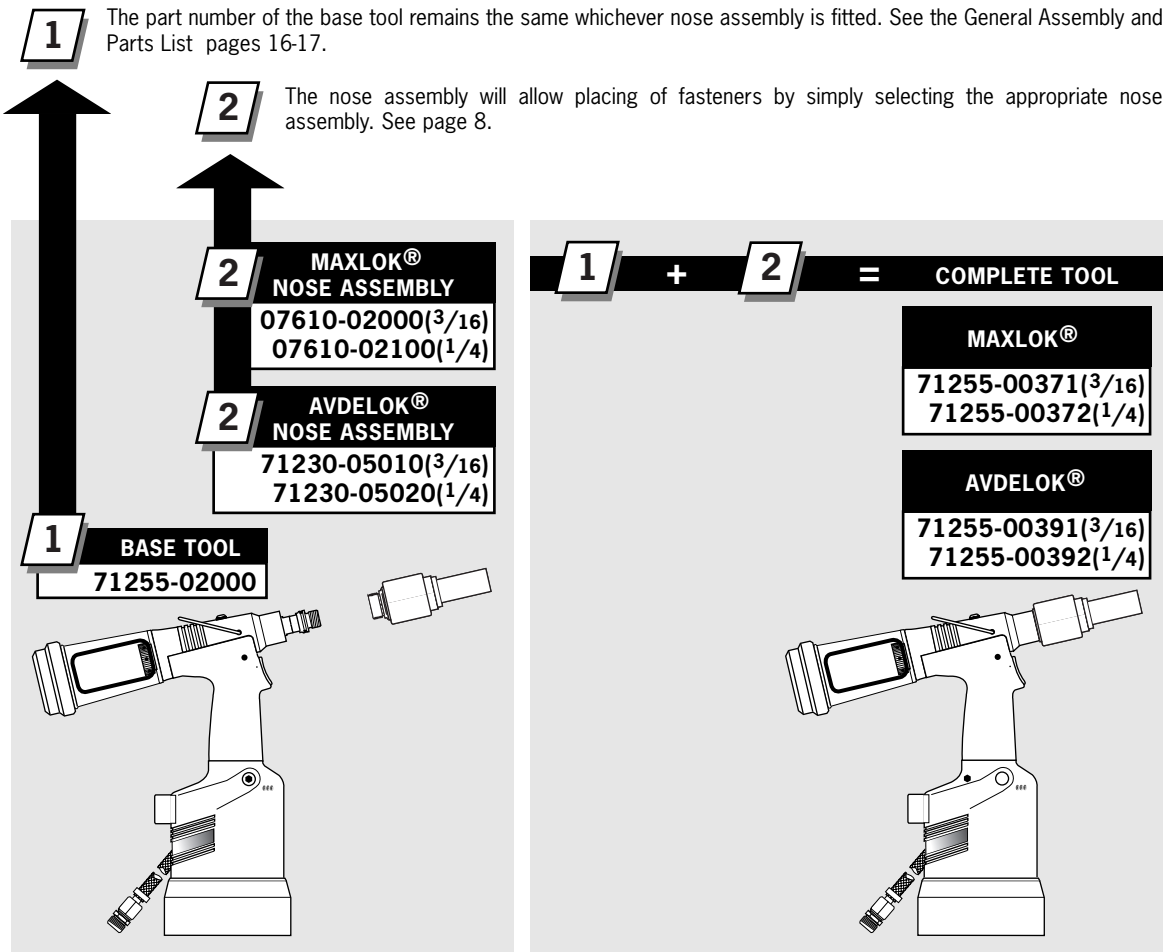

Putting into Service

Air Supply

All tools are operated with compressed air at an optimum pressure of 5.5 bar. We recommend the use of pressure regulators and automatic filtering systems on the main air supply. These should be fitted within 3 metres of the tool (see diagram below) to ensure maximum tool life and minimum tool maintenance.

Air supply hoses should have a minimum working effective pressure rating of 150% of the maximum pressure produced in the system or 10 bar, whichever is the highest. Air hoses should be oil resistant, have an abrasion resistant exterior and should be armoured where operating conditions may result in hoses being damaged. All air hoses MUST have a minimum bore diameter of 6.4 millimetres or 1/4 inch.

Read daily servicing details page 12.

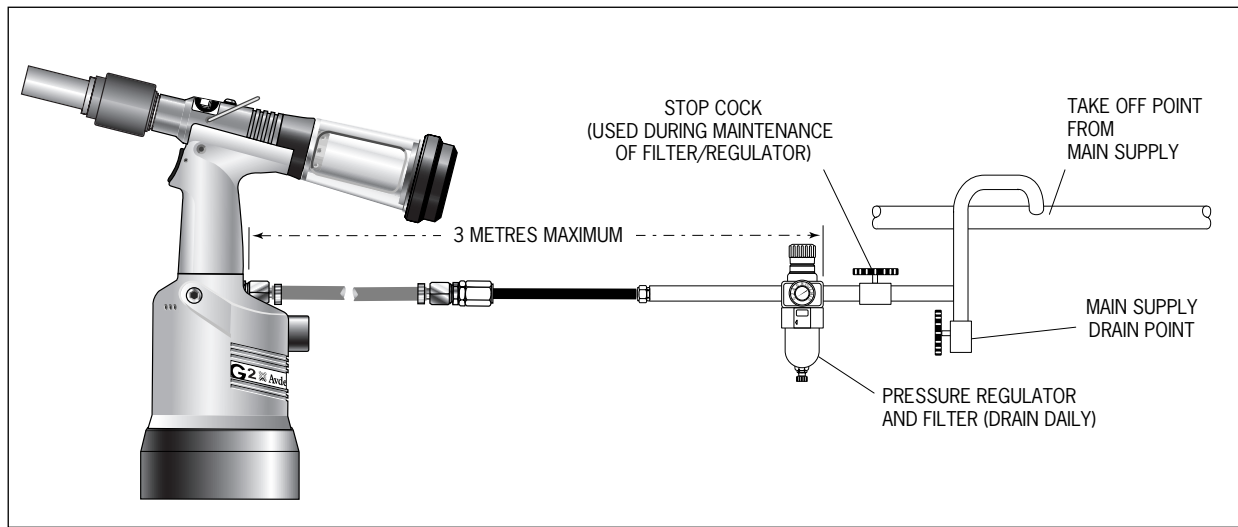

Operating Procedure

- Ensure that the correct nose assembly is fitted.
- Connect the tool to the air supply.
- Disable the vacuum extraction system by turning Rotary Valve **65** until you feel or hear no air flow out of the front of the nose assembly.
- Push the fastener stem through the application hole.
- Place the collar on the stem (orientation as shown).
- Keeping the head of the stem against the application, push the tool onto the protruding stem.
- Fully depress the trigger. One cycle will ensure that the collar is swaged into the lock grooves of the stem and that the stem breaks at the breaker groove.
- The tool completes its cycle by pushing itself off the collar and the spent stem will be pushed to the rear of the tool on insertion of the next fastener.

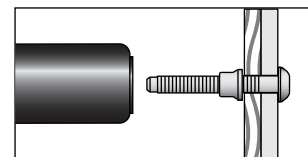

Placing AVDELOK®/MAXLOK®

Item numbers in **bold** refer to the General Assembly drawing and Parts List on pages 16-17.

Nose Assemblies

Avdelok® and Maxlok® Nose Assemblies

AVDELOK® NOSE ASSEMBLY

FASTENER			NOSE ASSEMBLY PART N°	see below
NAME	Ø ¹	MATERIAL		
AVDELOK®	3/16 ; 4.8	All	71230-05010	... 391
	1/4 ; 6.4	All	71230-05020	... 392

¹ In inches then in millimetres

COMPLETE TOOL PART NUMBER :
precede with 71255-00

**NOSE ASSEMBLY part n°
71230-05010 for 4.8 (3/16") Avdelok®**

ITEM	DESCRIPTION	PART N°
1	ANVIL CASING	71230-05012
2	BUFFER	71230-05014
3	ANVIL	71230-05011
4	SHROUD	71230-05013
5	CHUCK COLLET	07200-02101
6	CHUCK JAWS	07220-02102
7	SPRING GUIDE	07220-02104
8	SPRING	07220-02103
9	FRICTION RING	07610-02004
10	nG4 CHUCK COLLET ADAPTOR	07610-00501
11	nG4 LOCKNUT	71233-20200

**NOSE ASSEMBLY part n°
71230-05020 for 6.4 (1/4") Avdelok®**

ITEM	DESCRIPTION	PART N°
1	ANVIL CASING	71230-05012
2	BUFFER	71230-05014
3	ANVIL	71230-05021
4	SHROUD	71230-05013
5	CHUCK COLLET	07200-02201
6	CHUCK JAWS	07220-02302
7	SPRING GUIDE	07220-02104
8	SPRING	07220-02103
9	FRICTION RING	07610-02004
10	nG4 CHUCK COLLET ADAPTOR	07610-00501
11	nG4 LOCKNUT	71233-20200

MAXLOK® NOSE ASSEMBLY

FASTENER			NOSE ASSEMBLY PART N°	see below
NAME	Ø ¹	MATERIAL		
MAXLOK®	3/16 ; 4.8	All	07610-02000	... 371
	1/4 ; 6.4	Al Alloy	07610-02100	... 372

¹ In inches then in millimetres

COMPLETE TOOL PART NUMBER :
precede with 71255-00

**NOSE ASSEMBLY
part n° 07610-02000 for 3/16" ø**

ITEM	DESCRIPTION	PART N°
4	JAWS	07610-02003
7	SPRING	07610-02107
8	LOCKING RING	07610-02004
9	CHUCK COLLET	07610-02002
10	SPRING GUIDE	07220-02104
12	ANVIL	07610-02001
13	nG4 STOP NUT ASSY	71233-20200
14	nG4 CHUCK COLLET ADAPTOR	07610-00501
15	ANVIL ADAPTOR	71230-02063
16	ANVIL NUT	07610-00307

**NOSE ASSEMBLY
part n° 07610-02100 for 1/4" ø**

ITEM	DESCRIPTION	PART N°
4	JAWS	07610-02103
7	SPRING	07610-02107
8	LOCKING RING	07610-02004
9	CHUCK COLLET	07610-02102
10	SPRING GUIDE	07220-02104
12	ANVIL	07610-02101
13	nG4 STOP NUT ASSY	71233-20200
14	nG4 CHUCK COLLET ADAPTOR	07610-00501
15	ANVIL ADAPTOR	71230-02063
16	ANVIL NUT	07610-00307

READ MAXLOK® 'FITTING INSTRUCTIONS' PAGE 10.

Nose Assemblies

Fitting Instructions Avdelok®

IMPORTANT
Air supply must be disconnected when fitting or removing nose assemblies

- Assemble Chuck Jaws **6**, Spring Guides **7** and Spring **8** into Chuck Collet **5**. (Lightly coat Chuck Jaws and Chuck Collet internal bores with Molythium grease).
- Screw chuck collet (assembled as above) onto Chuck Collet Adaptor of tool assembly (item **1** page 16). Lock in position with Friction Ring **9**.
- Screw Anvil **3** into front of placing tool.
- Assemble Buffer **2** over Anvil **3** followed by Anvil Casing **1**.
- Fit rubber Shroud **4** over Anvil Casing **1** and Buffer **2** and locate over flange of Anvil **3** to hold components in position.

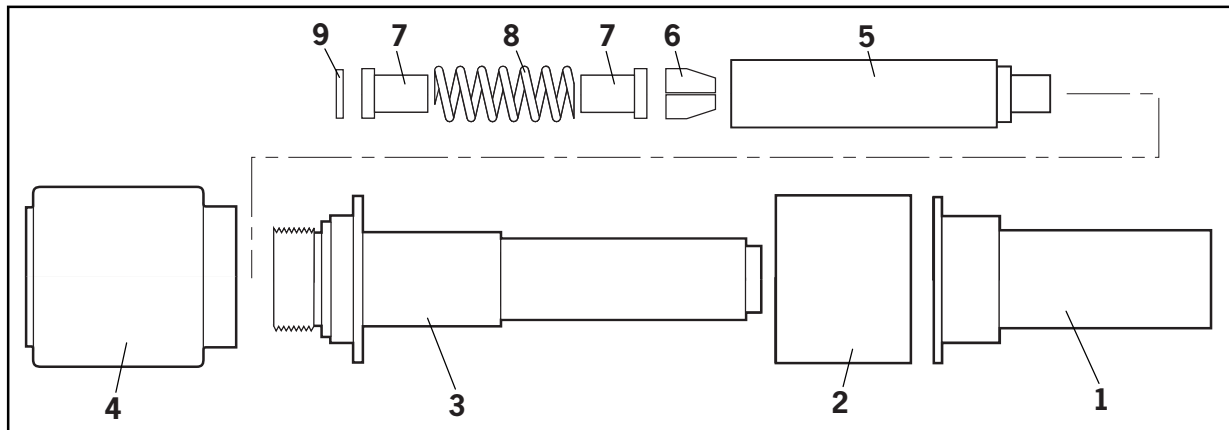

Servicing Instructions

- Remove nose assembly from tool using the reverse procedure to the fitting instructions above.
- Clean parts. Worn or damaged parts should be replaced.
- Check Anvil **3** for wear and/or damage to the swaging bore.
- Lightly coat Chuck Jaws **6** and Chuck Collet **5** internal bores with Molythium grease.
- Assemble as above instructions.
- For ease of fitting the rubber shroud, liquid soap can be smeared on its internal surface prior to assembly.

Item numbers in **bold** refer to the Avdelok® Nose Assembly on page 8.

Nose Assemblies

Fitting Instructions Maxlok®

IMPORTANT

Air supply must be disconnected when fitting or removing nose assemblies

- Fit Locking Ring **8** onto the Chuck Collet Adaptor.
- Lightly coat Jaws **4** with Moly Lithium grease.
- Drop Jaws **4** into Chuck Collet **9**.
- Insert one Spring Guide **10** into Chuck Collet **9**.
- Locate Spring **7** onto the Spring Guide **10** already in place.
- Drop the other Spring Guide **10** into Spring **7**.
- Holding tool pointing down, screw the assembled Chuck Collet onto the Chuck Collet Adaptor and tighten with spanner.
- Screw Anvil Adaptor **15** into the Head Assembly.
- Place Anvil **12** over Chuck Collet **9** and lock into place with Anvil Nut **16**.

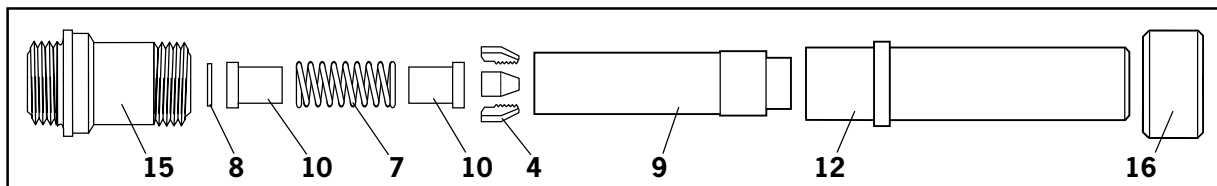

Servicing Instructions

- Remove nose assembly from tool using the reverse procedure to the fitting instructions above.
- Clean parts. Worn or damaged parts should be replaced.
- Check the Anvil **12** for wear and/or damage to the swaging bore.
- Lightly coat Chuck Jaws **4** and Chuck Collet **9** internal bores with Molythium grease.
- Assemble as above instructions.

Item numbers in **bold** refer to the Maxlok® Nose Assembly on page 8.

Accessories

Stem Deflector

The stem deflector is a very simple alternative to the standard stem collector and allows access in restricted areas. It is easy to fit to the tool as follows:

- Unscrew Retaining Nut **26** by inserting a 3 millimetre diameter rod into one of the holes.
- Remove Retaining Nut **26** and the stem collector assembly, items **18, 20, 21, 22, 23, 24,** and **25**.
- Push the boss end of the stem deflector into the internal groove of the adaptor nut.
- Rotate the stem deflector until the aperture faces away from the operator and other person(s) in the vicinity.

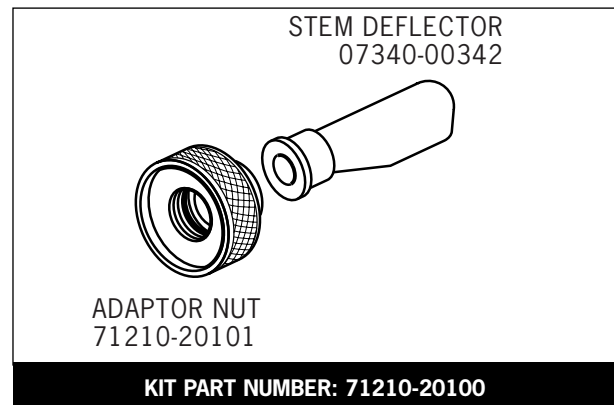

Extension

Fitted between the tool and the nose assembly the extension allows access into deep channels.

- To fit the extension, remove any nose assembly components.
- Screw the inner extension to Chuck Collet Adaptor **1**.
- Screw the outer onto Head Assembly **4**.
- Fit the nose assembly onto the extension.

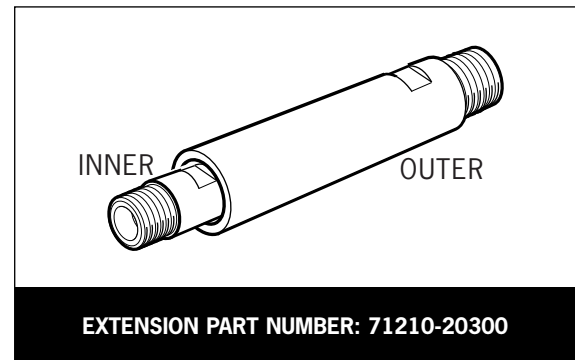

Item numbers in **bold** refer to the General Assembly drawing and Parts List on pages 16 and 17.

Servicing the Tool

I M P O R T A N T

Read Safety Instructions on page 4.

The employer is responsible for ensuring that tool maintenance instructions are given to the appropriate personnel.

The operator should not be involved in maintenance or repair of the tool unless properly trained.

The tool shall be examined regularly for damage and malfunction.

Daily

- Check for air leaks. If damaged, hoses and couplings should be replaced.
- If there is no filter on the pressure regulator, bleed the air line to clear it of accumulated dirt or water before connecting the air hose to the tool. If there is a filter, drain it.
- Check that the nose assembly is correct for the fastener to be placed.
- Check that the stroke of the tool meets the minimum specification (page 5). The last step of the Priming Procedure on page 19 explains how to measure the stroke.
- Either a stem collector or a stem deflector must be fitted to the tool.
- Ensure that Rotary Valve **65** is turned OFF.

Weekly

- Dismantle and clean nose assembly, with special attention to the jaws. Lubricate with Moly Lithium grease EP 3753 before assembling.
- Check for air leaks.

Moly Lithium Grease EP 3753 Safety Data

Grease can be ordered as a single item, the part number is shown in the Service Kit page 13.

First Aid

SKIN:

As the grease is completely water resistant it is best removed with an approved emulsifying skin cleaner.

INGESTION:

Ensure the individual drinks 30ml Milk of Magnesia, preferably in a cup of milk.

EYES:

Irritant but not harmful. Irrigate with water and seek medical attention.

Fire

FLASH POINT: Above 220°C.

Not classified as flammable.

Suitable extinguishing media: CO₂, Halon or water spray if applied by an experienced operator.

Environment

Scrape up for burning or disposal on approved site.

Handling

Use barrier cream or oil resistant gloves

Storage

Away from heat and oxidising agent.

Item numbers in **bold** refer to the General Assembly drawing and Parts List on pages 16-17.

Servicing the Tool

Molykote® 55m Grease Safety Data

First Aid

SKIN:

Flush with water. Wipe off.

INGESTION:

No first aid should be needed.

EYES:

Flush with water.

Fire

FLASH POINT: Above 101.1°C. (closed cup)

Explosive Properties: No

Suitable Extinguishing Media: Carbon Dioxide Foam, Dry Powder or fine water spray.

Water can be used to cool fire exposed containers.

Environment

Do not allow large quantities to enter drains or surface waters.

Methods for cleaning up: Scrape up and place in suitable container fitted with a lid. The spilled product produces an extremely slippery surface.

Harmful to aquatic organisms and may cause long-term adverse effects in the aquatic environment. However, due to the physical form and water - insolubility of the product the bioavailability is negligible.

Handling

General ventilation is recommended. Avoid skin and eye contact.

Storage

Do not store with oxidizing agents. Keep container closed and store away from water or moisture.

Molykote® 111 Grease Safety Data

First Aid

SKIN:

No first aid should be needed.

INGESTION:

No first aid should be needed.

EYES:

No first aid should be needed.

INHALATION:

No first aid should be needed.

Fire

FLASH POINT: Above 101.1°C. (closed cup)

Explosive Properties: No

Suitable Extinguishing Media: Carbon Dioxide Foam, Dry Powder or fine water spray.

Water can be used to cool fire exposed containers.

Environment

No adverse effects are predicted.

Handling

General ventilation is recommended. Avoid eye contact.

Storage

Do not store with oxidizing agents. Keep container closed and store away from water or moisture.

Servicing the Tool

Annually

(or every 500,000 cycles whichever is the soonest)

Annually or every 500,000 cycles the tool should be completely dismantled and new components should be used where worn, damaged or recommended. All 'O' rings and seals should be renewed and lubricated with Molykote® 55m grease for pneumatic sealing or Molykote® 111 for hydraulic sealing.

For an easy complete service, Avdel® is offering a complete service kit.

SERVICE KIT : 71210-99990		Spanners are specified in inches and across flats unless otherwise stated	
PART N°	DESCRIPTION	PART N°	DESCRIPTION®
07900-00667	PISTON SLEEVE	07900-00164	CIRCLIP PLIERS
07900-00692	TRIGGER VALVE EXTRACTOR	07900-00008	7/16 x 1/2 SPANNER
07900-00670	BULLET	07900-00012	9/16 x 5/8 SPANNER
07900-00672	'T' SPANNER	07900-00015	5/8 x 11/16 SPANNER
07900-00706	'T' SPANNER SPIGOT	07900-00686	PEG SPANNER
07900-00684	GUIDE TUBE	07900-00677	SEAL EXTRACTOR
07900-00685	INSERTION ROD	07900-00698	STOP NUT
07900-00351	3 MM ALLEN KEY	07900-00700	PRIMING PUMP
07900-00469	2.5 MM ALLEN KEY	07992-00020	GREASE - MOLY LITHIUM E.P.3753
07900-00158	2 MM PIN PUNCH	07992-00075	GREASE - MOLYKOTE® 55M
07900-00224	4 MM A/F ALLEN KEY	07900-00755	GREASE - MOLYKOTE® 111
07900-00734	STOP NUT - MAXLOK®		

IMPORTANT

Read Safety Instructions on page 4.
The employer is responsible for ensuring that tool maintenance instructions are given to the appropriate personnel.
The operator should not be involved in maintenance or repair of the tool unless properly trained.
The tool should be examined regularly for damage and malfunction.

The airline must be disconnected before any servicing or dismantling is attempted unless specifically instructed otherwise.

It is recommended that any dismantling operation be carried out in clean conditions.

Before proceeding with dismantling, empty the oil from the tool following the first three steps of the 'Priming Procedure' on page 19.

Prior to dismantling the tool it is necessary to remove the nose equipment. For instructions see the Nose Assemblies section, pages 8, 9 and 10.

For a complete service of the tool, we advise that you proceed with dismantling of sub-assemblies in the order shown.

After any dismantling REMEMBER to prime the tool and to fit an appropriate nose assembly.

Head Assembly

- Unscrew Retaining Nut **26** and pull off stem collector assembly, items **18, 20, 21, 22, 23, 24** and **25**.
- Using the 'T' spanner*, remove End Cap Assembly **73** together with Seal **17**, 'O' Ring **16**, Lip Seal **28** and Spring **70**.
- Loosen Locknut **3** with a spanner* then unscrew Chuck Collet Adaptor **1**.
- Remove Locknut **3** together with 'O' rings **49** and **50**.
- Remove screw **9** and Bonded Seal **10**.
- Push Head Piston **7** to the rear and out of Head Assembly **4** taking care not to damage the cylinder bore.
- Remove Seal Retainer **30**. Push Lip Seal **8** to the rear and out of Head Assembly **4** taking care again not to damage the cylinder bore.
- Remove Seal Housing **5** and Lip Seal **67**.

* Item included in the Service Kit.

Item numbers in **bold** refer to the General Assembly drawing and Parts List on pages 16-17.

Servicing the Tool

Head Assembly

Assemble in reverse order to dismantling noting the following points:

- Place Lip Seal **8** onto the insertion rod* ensuring correct orientation. Push the guide tube* into the head of the tool and push the insertion rod* with the seal into place through the guide tube*. Pull the insertion rod* out then the guide tube.
- Drop Seal Retainer **30** against Lip Seal **8** large flange first.
- Fit Lip Seal **11** and 'O' Ring **13** (2 off) onto the head piston **7**.
- Lubricate the cylinder bore and place the piston sleeve* into the back of Head Assembly **4**. Slide the bullet* onto the threaded part of Head Piston **7** and push the piston with the seals through the piston sleeve* as far as it will go. Slide the bullet* off the piston and remove the piston sleeve.
- Fit Seal Housing **5** and Lip Seal **67**.
- Tighten Chuck Collet Adaptor **1** fully tightened onto Head Piston **7** BEFORE tightening Locknut **3** against it.
- Use Loctite® 932 when reassembling Retaining Nut **26**.

Pneumatic Piston Assembly

- Remove 'ON/OFF' Valve Assembly **60**.
- Clamp the body of the inverted tool **ACROSS THE AIR INLET BOSSES** in a vice fitted with soft jaws.
- Pull off Rubber Boot **80**.
- Using the peg spanner* unscrew Base Cover **40**.
- Unscrew Locknuts **76** (2 off) and remove Base Plate **77**.
- Remove Cylinder Liner **45** together with Sealing Washers **75** (2 off) and 'O' Rings **78** (2 off).
- Remove Pneumatic Piston Assembly **42** together with 'O' Ring **39**, Lip Seals **41** (3 off) and Guide Ring **35**.
- Engage the Seal Extractor* into Seal Assembly **34** and withdraw Seal Assembly from intensifier tube of the Head Assembly **4**.

Assemble in reverse order.

Valve Spool Assembly

- Remove Pneumatic Piston Assembly **42** and Intensifier Seal Assembly **34** as described above.
- Using the 'T' spanner* and 'T' spanner spigot* undo Clamp Nut **36** and remove it together with Top Plate **63**, Transfer Tube Assembly **44**, 'O' ring **6** and Silencers **62**.
- Release the tool from the vice and separate Body **38** with 'O' Ring **31** from Handle Assembly **32**.
- Remove 'O' Ring **33** from the intensifier tube and pull off Head Assembly **4** from Handle Assembly **32**.
- Push out Valve Seat **64** with 'O' Ring **6**.
- Pull out all the components of Valve Spool Assembly **54**.
- Finally remove 'O' Ring **59** out of the handle counterbore.

Assemble in reverse order noting the following points -

- Ensure that the central port in Valve Seat **64** faces upwards.
- Use Loctite® 243 when reassembling Clamp Nut **36**, torque to 11ft lb (14.91 Nm).

Trigger

- Using the 2 millimetre diameter pin punch*, drive Trigger Pin **48** out and lift off Trigger **47**.
- Unscrew Trigger Valve **46** using the trigger valve extractor*.

Assemble in reverse order to dismantling.

IMPORTANT

**Check the tool against daily and weekly servicing
Priming is ALWAYS necessary after the too has been dismantled and prior to operating.**

* Item included in the Service Kit. For complete list see page 14.
Item numbers in **bold** refer to the General Assembly drawing and Parts List on pages 16-17.

Parts List for 71255-02000

71255-02000 PARTS LIST									
* These are minimum recommended levels of spares based on regular servicing									
ITEM	PART N°	DESCRIPTION	QTY	SPARES	ITEM	PART N°	DESCRIPTION	QTY	SPARES
01	07610-00501	CHUCK COLLET ADAPTOR	1	1	48	71210-02024	TRIGGER PIN	1	2
03	71230-02015	LOCKNUT	1	-	49	07003-00310	'O' RING	2	1
04	71230-03300	HEAD ASSEMBLY	1	-	50	07003-00204	'O' RING	1	-
05	71210-02104	SEAL HOUSING	1	3	52	07003-00127	'O' RING	1	-
06	07003-00281	'O' RING	3	-	53	07005-01274	1/8" BSP PLUG	1	-
07	71231-02003	HEAD PISTON	1	1	54	71210-03400	VALVE SPOOL ASSEMBLY (55 to 58)	1	2
08	07003-00273	LIP SEAL	1	1	55	07003-00268	• 'O' RING	1	-
09	71230-02041	SCREW	1	2	56	71210-03402	• VALVE SPOOL	1	-
10	07003-00194	BONDED SEAL	1	1	57	71210-03401	• VALVE BODY	1	2
11	07003-00341	LIP SEAL	1	2	58	07003-00042	• 'O' RING	1	1
13	07003-00342	'O' RING	2	1	59	07003-00271	'O' RING	1	-
14	71210-02022	SUSPENSION RING	1	1	60	71210-03700	ON/OFF VALVE ASSEMBLY	1	-
16	07003-00278	'O' RING	1	1	61	07008-00010	6" FLEXIBLE HOSE	1	2
17	71210-02029	SEAL	1	1	62	71210-02031	SILENCER	2	-
18	07003-00311	'O' RING	1	-	63	71221-02003	TOP PLATE	1	1
20	07640-00239	STEM COLLECTOR OUTER #	1	-	64	71210-02009	VALVE SEAT	1	-
21	71210-02051	STEM COLLECTOR BODY #	1	1	65	71210-02013	ROTARY VALVE	1	2
22	07640-00244	SILENCER #	1	-	66	07003-00189	'O' RING	2	-
23	71210-02034	SILENCER CAP #	1	-	67	07003-00333	LIP SEAL	1	1
24	07340-00335	STEM COLLECTOR END CAP #	1	1	69	07007-00224	SPIROL PINS	2	-
25	71210-02035	SILENCER #	1	-	70	07490-03002	SPRING	1	-
26	71210-02028	RETAINING NUT	1	-	72	71403-02110	BOTTLE ADAPTOR ASSEMBLY	1	-
28	07003-00374	LIP SEAL	1	-	73	71231-02001	END CAP ASSEMBLY	1	-
30	71230-02019	SEAL RETAINER	1	-	74	71211-02004	TIE ROD	2	-
31	07003-00288	'O' RING	1	2	75	71221-02006	SEALING WASHER	2	-
32	71221-02013	HANDLE ASSEMBLY	2	1	76	07002-00108	M6 NYLON NUT	2	-
33	07003-00287	'O' RING	1	1	77	71221-02005	BASE PLATE	1	-
34	71230-03800	INTENSIFIER SEAL ASSEMBLY	1	-	78	07003-00027	'O' RING	2	-
35	71230-03205	GUIDE RING	1	-	79	71221-02003	TOP PLATE	1	-
36	71210-02014	CLAMP NUT	1	1	80	71210-02055	RUBBER BOOT	1	-
37	71255-02027	LABEL	1	-	81	07007-01993	CENTRE POLE MAGNET	1	-
38	71211-02001	BODY	1	1	82	71221-20104	M5 X 19 COUNTERSUNK SCREW	1	-
39	07003-00280	'O' RING	1	-	83	07002-00098	M5 NYLON NUT	1	-
40	71211-02002	BASE COVER	1	1	84	71221-20105	COUNTER	1	-
41	07003-00274	LIP SEAL	3	-	85	71221-20101	COUNTER MouldING	1	-
42	71255-03200	PNEUMATIC PISTON ASSEMBLY (INCLUDES 41/35/39)	1	-	86	71221-20102	SPECIAL M4 SCREW	2	-
44	71210-03600	TRANSFER TUBE ASSEMBLY	1	-	87	71221-20103	MOULD RETAINING NUT	2	-
45	71211-02008	CYLINDER LINER	1	-	88	07007-01503	LABEL BOOK SYMBOL	1	-
46	07005-00088	TRIGGER VALVE	1	-					
47	71210-02008	TRIGGER	1	-					

These items are also available as a complete kit. Part Number 71210-20400.

Priming

Priming is ALWAYS necessary after the tool has been dismantled and prior to operating. It may also be necessary to restore the full stroke after considerable use, when the stroke may be reduced and fasteners are not fully placed by one operation of the trigger.

Oil Details

The recommended oil for priming is Hyspin® VG32 available in 0.5l (part number 07992-00002) or one gallon containers (part number 07992-00006). Please see safety data below.

Hyspin® VG 32 Oil Safety Data

First Aid

SKIN:

Wash thoroughly with soap and water as soon as possible. Casual contact requires no immediate attention. Short term contact requires no immediate attention.

INGESTION:

Seek medical attention immediately. DO NOT induce vomiting.

EYES:

Irrigate immediately with water for several minutes. Although NOT a primary irritant, minor irritation may occur following contact.

Fire

Flash point 232°C. Not classified as flammable.

Suitable extinguishing media: CO₂, dry powder, foam or water fog. DO NOT use water jets.

Environment

WASTE DISPOSAL: Through authorised contractor to a licensed site. May be incinerated. Used product may be sent for reclamation.

SPILLAGE: Prevent entry into drains, sewers and water courses. Soak up with absorbent material.

Handling

Wear eye protection, impervious gloves (e.g. of PVC) and a plastic apron. Use in well ventilated area.

Storage

No special precautions.

Priming Kit

To enable you to follow the priming procedure opposite, you will need to obtain a priming kit:

PRIMING KIT : 07900-00688	
PART N°	DESCRIPTION
07900-00351	3mm ALLEN KEY
07900-00698	STOP NUT
07900-00700	PRIMING PUMP
07900-00224	4mm ALLEN KEY
07900-00734	MAXLOK® STOP NUT

Priming

Priming Procedure

I M P O R T A N T

**DISCONNECT THE TOOL FROM THE AIR SUPPLY OR SWITCH OFF AT VALVE 55.
REMOVE NOSE ASSEMBLY.**

**All operations should be carried out on a clean bench, with clean hands in a clean area.
Ensure that the new oil is perfectly clean and free from air bubbles.**

Care MUST be taken at all times, to ensure that no foreign matter enters the tool, or serious damage may result.

- Remove bleed Screw **9** and Bonded Seal **10**.
- Connect air supply to tool and switch ON/OFF Valve Assembly **60** to "ON" position.
- Invert tool over suitable container and actuate trigger. Waste oil will be ejected through the bleed screw hole.

CARE SHALL BE TAKEN TO ENSURE THAT THE BLEED HOLE IS NOT DIRECTED TOWARDS THE OPERATOR OR OTHER PERSONNEL.

- Screw stop nut 07900-00734 onto Chuck Collet Adaptor **1**.
- Disconnect air supply to tool or switch ON/OFF Valve Assembly **60** to "OFF" position.
- Fill the priming pump with oil.
- Screw priming pump 07900-00700 into the bleed screw hole with Bonded Seal **10** in place.
- Actuate the priming pump by pressing down and releasing several times until resistance is felt.
- Remove the priming pump and the stop nut.
- Replace bleed Screw **9** and Bonded Seal **10**.
- Connect air supply to tool and switch ON/OFF Valve Assembly **60** to "ON" position.
- Check that the stroke of the tool meets the minimum specification of 13 millimetres. To check the stroke, measure the distance between the front face of Chuck Collet Adaptor **1** and the front face of the head, BEFORE pressing the trigger and when the trigger is fully actuated. The stroke is the difference between the two measurements. If it does not meet the minimum specification, repeat the priming procedure.

Item numbers in **bold** refer to the General Assembly drawing and Parts List on pages 16-17.

Fault Diagnosis

Symptom	Possible Cause	Remedy	Page Ref
More than one operation of the trigger needed to place fastener	Air leak	Tighten joints or replace components	
	Insufficient air pressure	Adjust air pressure to within specification	5
	Worn or broken jaws	Fit new jaws	9
	Low oil level or air in oil	Prime tool	18-19
	Build up of dirt inside the nose assembly	Service	9
Tool will not grip stem of fastener	Worn or broken jaws	Fit new jaws	9
	Build up of dirt inside the nose assembly	Service	9
	Loose jaw housing or chuck collet	Tighten against locking ring	9
	Weak or broken spring in nose assembly	Fit new spring	9
	Incorrect component in nose assembly	Identify and replace	9
Jaws will not release broken stem of fastener	Build up of dirt inside the nose assembly	Service	12
	chuck collet.		
		Tighten nose assembly	9
	Weak or broken spring in nose assembly	Fit new spring	8-9
	Air or oil leak	Tighten joints or replace components	
	Low oil level or air present in oil	Prime tool	18-19
Cannot feed next fastener	Broken stems jammed inside tool	Empty stem collector	4 (point 14)
		Check correct equipment is fitted	8-9
		Adjust air pressure to within specification	5
Slow cycle	Low air pressure	Adjust air pressure to within the specification	5
	Build up of dirt inside the nose assembly	Service	12
Tool fails to operate	No air pressure	Connect and adjust to within the specification	5
	Damaged Trigger Valve 46	Replace	15
	Loose stem collector	Tighten Retaining Nut 26	15
Fastener fails to break	Insufficient air pressure	Adjust air pressure to within specification	5
	Fastener outside tool capability	Use more powerful Genesis tool.	
		Contact Avdel Uk Limited	
	Low oil level or air present in oil	Prime tool	18-19
Tool fails to swage collar	Insufficient air pressure	Adjust air pressure to within specification	5
	Worn or damaged anvil	Replace	8-9
	Low oil level or air present in oil	Prime tool	18-19

Item numbers in **bold** refer to the General Assembly drawing and Parts List on pages 16-17.

Other symptoms or failures should be reported to your local Avdel authorised distributor or repair centre.

Notes

Notes

Declaration of Conformity

We, Avdel UK Limited, Watchmead Industrial Estate, Welwyn Garden City, Herts, AL7 1LY declare under our sole responsibility that the product:

Model G2LB

Serial No. 

to which this declaration relates is in conformity with the following standards:

EN ISO 12100 - parts 1 & 2	
BS EN ISO 8662 - part 6	BS EN ISO 11202
BS EN ISO 3744	BS EN 982
ISO EN 792 part 13 - 2000	BS EN 983

following the provisions of the Machine Directive 98/37/EC

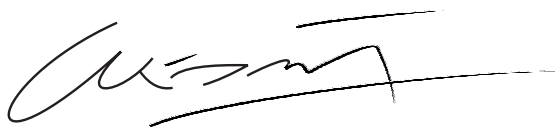

A. Seewraj - Product Engineering Manager - Automation Tools

Date of issue



This box contains a power tool which is in conformity with Machines Directive 98/37/EC. The 'Declaration of Conformity' is contained within.



An Acument™ Global Technologies Company

AUSTRALIA

Acument Australia Pty Ltd.

891 Wellington Road
Rowville, Victoria 3178
Tel: +61 3 9765 6400
Fax: +61 3 9765 6445
Email: info@acument.com.au

CANADA

Avdel Canada, a Division of Acument Canada Limited.

87 Disco Road
Rexdale
Ontario M9W 1M3
Tel: +1 416 679 0622
Fax: +1 416 679 0678
Email: infoAvdel-Canada@acument.com

CHINA

Acument China Ltd.

RM 1708, 17/F., Nanyang Plaza,
57 Hung To Rd., Kwun Tong
Hong Kong
Tel: +852 2950 0631
Fax: +852 2950 0022
Email: infochina@acument.com

FRANCE

Avdel France S.A.S.

33 bis, rue des Ardennes
BP4
75921 Paris Cedex 19
Tel: +33 (0) 1 4040 8000
Fax: +33 (0) 1 4208 2450
Email: AvdelFrance@acument.com

GERMANY

Avdel Deutschland GmbH

Klusriede 24
30851 Langenhagen
Tel: +49 (0) 511 7288 0
Fax: +49 (0) 511 7288 133
Email: AvdelDeutschland@acument.com

ITALY

Avdel Italia S.r.l.

Viale Lombardia 51/53
20047 Brugherio (MI)
Tel: +39 039 289911
Fax: +39 039 2873079
Email: vendite@acument.com

JAPAN

Acument Japan Kabushiki Kaisha

Center Minami SKY,
3-1 Chigasaki-Chuo, Tsuzuki-ku,
Yokohama-city, Kanagawa Prefecture
Japan 224-0032
Tel: +81 45 947 1200
Fax: +81 45 947 1205
Email: info@acument.co.jp

SINGAPORE

Acument Asia Pacific (Pte) Ltd.

#05-03/06 Techlink
31 Kaki Bukit Road 3
Singapore, 417818
Tel: +65 6840 7431
Fax: +65 6840 7409
Email: Tlim@acument.com

SOUTH KOREA

Acument Korea Ltd.

212-4, Suyang-Ri,
Silchon-Eup, Kwangju-City,
Kyunggi-Do, Korea, 464-874
Tel: +82 31 798 6340
Fax: +82 31 798 6342
Email: info@acumentkorea.com

SPAIN

Avdel Spain S.A.

C/ Puerto de la Morcuera, 14
Poligono Industrial Prado Overa
Ctra. de Toledo, km 7,8
28919 Leganés (Madrid)
Tel: +34 (0) 91 3416767
Fax: +34 (0) 91 3416740
Email: ventas@acument.com

UNITED KINGDOM

Avdel UK Limited

Pacific House
2 Swiftfields
Watchmead Industrial Estate
Welwyn Garden City
Hertfordshire
AL7 1LY
Tel: +44 (0) 1707 292000
Fax: +44 (0) 1707 292199
Email: enquiries@acument.com

USA

Avdel USA LLC

614 NC Highway 200 South
Starfield,
North Carolina 28163
Tel: +1 704 888-7100
Fax: +1 704 888-0258
Email: infoAvdel-USA@acument.com

© 2008 Acument Intellectual Properties, LLC.

Manual No.	Issue	Change Note No.	Date
07900-00834	A	04/065	06/04
	B	07/044	02/07
	B2	07-103	03/07
	B3	08-096	07/08

Avdel®, Avdel® SR, Avex®, Avibulb®, Avinox®, Avseal®, Avtainer®, Bulbex®, Cherrymate®, Hemlock®, Interlock®, MBC®, Maxlok®, Q-Rivet™, Stavex®, T-Lok®, TLR®, T Rivet™, are trademarks of Avdel UK Limited.

www.avdel-global.com