

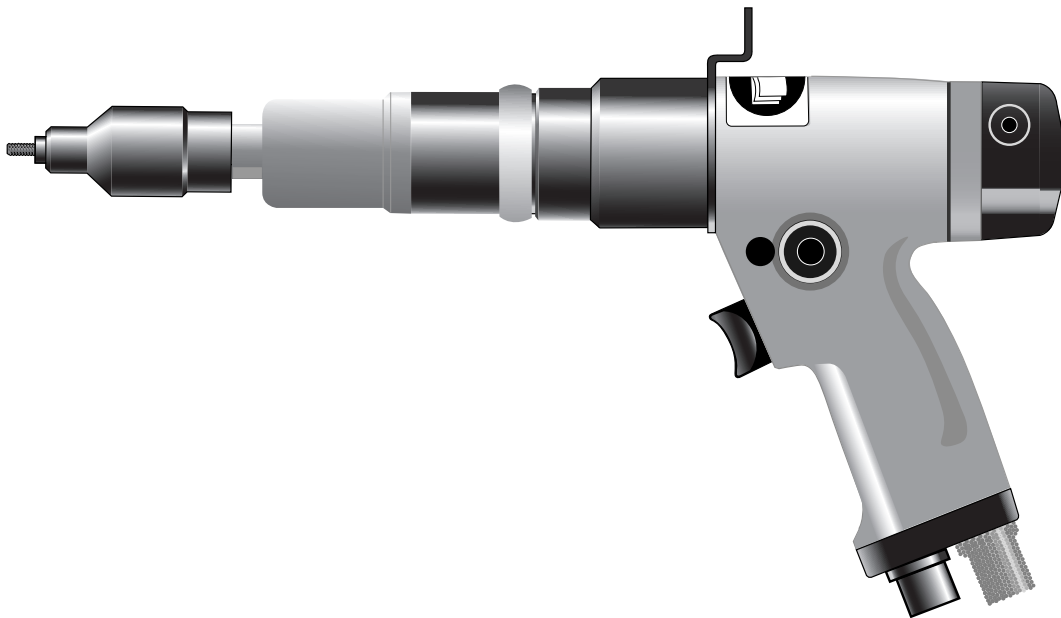

An Acument™ Global Technologies Company

# Instruction Manual



74110

**Threaded Insert Power Tool**



# Contents

---

<b>Safety Rules</b>	4
<b>Tool Specifications</b>	5
Tool Dimensions	5
<b>Intent of Use</b>	
Tool Selection	6 & 7
<b>Putting into Service</b>	
Air supply	8
Operating Procedure	8
Clutch Adjustment	9
Accessories	9
<b>Nose Assemblies</b>	
Fitting Instructions	10
Servicing Instructions	10
Nose Assembly Components	11 & 12
<b>Servicing the Tool</b>	
Daily Servicing	13
Weekly Servicing	13
<b>Safety Data (Grease)</b>	14
<b>Maintenance</b>	
Reset Clutch Torque	15
Clutch Assembly	16
Gearbox Assembly	17
Motor Assembly	18
Setting the Push Rod	19
<b>General Assembly of Base Tool</b>	20, 22
<b>Parts List</b>	21, 23
<b>Troubleshooting</b>	24 & 25

## Warranty

**Avdel installation tools carry a 12 month warranty against defects caused by faulty materials or workmanship, the warranty period commencing from the date of delivery confirmed by invoice or delivery note.**

**The warranty applies to the user/purchaser when sold through an authorised outlet, and only when used for the intended purpose. The warranty is invalidated if the installation tool is not serviced, maintained and operated according to the instructions contained in the Instruction and Service Manuals.**

**In the event of a defect or failure, and at its sole discretion, Avdel undertakes only to repair or replace faulty components.**

Avdel UK Limited policy is one of continuous product development and improvement and we reserve the right to change the specification of any product without prior notice.

# Safety Rules

**This instruction manual must be read with particular attention to the following safety rules, by any person installing, operating, or servicing this tool.**

- 1 Do not use outside the design intent.
- 2 Do not use equipment with this tool other than that recommended and supplied by Avdel UK Limited.
- 3 Any modification undertaken by the customer to the tool/machine, nose assemblies, accessories or any equipment supplied by Avdel UK Limited or their representatives, shall be the customer's entire responsibility. Avdel UK Limited will be pleased to advise upon any proposed modification.
- 4 The tool/machine must be maintained in a safe working condition at all times and examined at regular intervals for damage and function by trained competent personnel. Any dismantling procedure shall be undertaken only by personnel trained in Avdel UK Limited procedures. Do not dismantle this tool/machine without prior reference to the maintenance instructions. Please contact Avdel UK Limited with your training requirements.
- 5 The tool/machine shall at all times be operated in accordance with relevant Health and Safety legislation. In the U.K. the "Health and Safety at Work etc. act 1974" applies. Any question regarding the correct operation of the tool/machine and operator safety should be directed to Avdel UK Limited.
- 6 The precautions to be observed when using this tool/machine must be explained by the customer to all operators.
- 7 Always disconnect the airline from the tool/machine inlet before attempting to adjust, fit or remove a nose assembly.
- 8 Do not operate a tool/machine that is directed towards any person(s).
- 9 Ensure that vent holes do not become blocked or covered and that hoses are always in good condition.
- 10 The operating pressure shall not exceed 6.3 bar - 94 lbf/in<sup>2</sup>.
- 11 Do not operate the tool without full nose equipment in place.
- 12 When using the tool, the wearing of safety glasses is required both by the operator and others in the vicinity to protect against fastener projection, should a fastener be placed 'in air'. We recommend wearing gloves if there are sharp edges or corners on the application.
- 13 Take care to avoid entanglement of loose clothes, ties, long hair, cleaning rags etc. in the moving parts of the tool which should be kept dry and clean for best possible grip.
- 14 When carrying the tool from place to place keep hands away from the trigger/lever to avoid inadvertent start up.
- 15 Always adopt a firm footing or a stable position before operating the tool and be aware of a torque reaction on the hands when the tool is operating, particularly during the reversing sequence. Grip the tool firmly to be able to counter the torque reaction, but not too tightly.
- 16 Keep hands away from the rotating drive screw and the nose end of the tool. If a fastener becomes jammed on the drive screw, shut off the air supply and drain the supply line to the tool before attempting to dislodge it.
- 17 The tool is not electrically insulated.
- 18 This tool is not designed for use in combustible or explosive atmospheres.

# Specifications

## Tool Specification

<b>Air Pressure</b>	Minimum - Maximum	4-6.3 bar (60/94 lbf/in <sup>2</sup> )
<b>Free Air Volume Required</b>	@ 6.3 bar / 94 lbf/in <sup>2</sup>	7.5 litres/sec
<b>Motor Speed</b>	@ 75 lb/in <sup>2</sup> minimum	600 rpm (clockwise)
<b>Cycle time</b>	Approx	3 seconds
<b>Noise Level</b>		82 dB(A)
<b>Weight</b>	Without nose equipment	1.6 kg 3.53 lb
<b>Vibration</b>	Less than	2.5 m/s <sup>2</sup> (8 ft/s <sup>2</sup> )

## Tool Dimensions

---

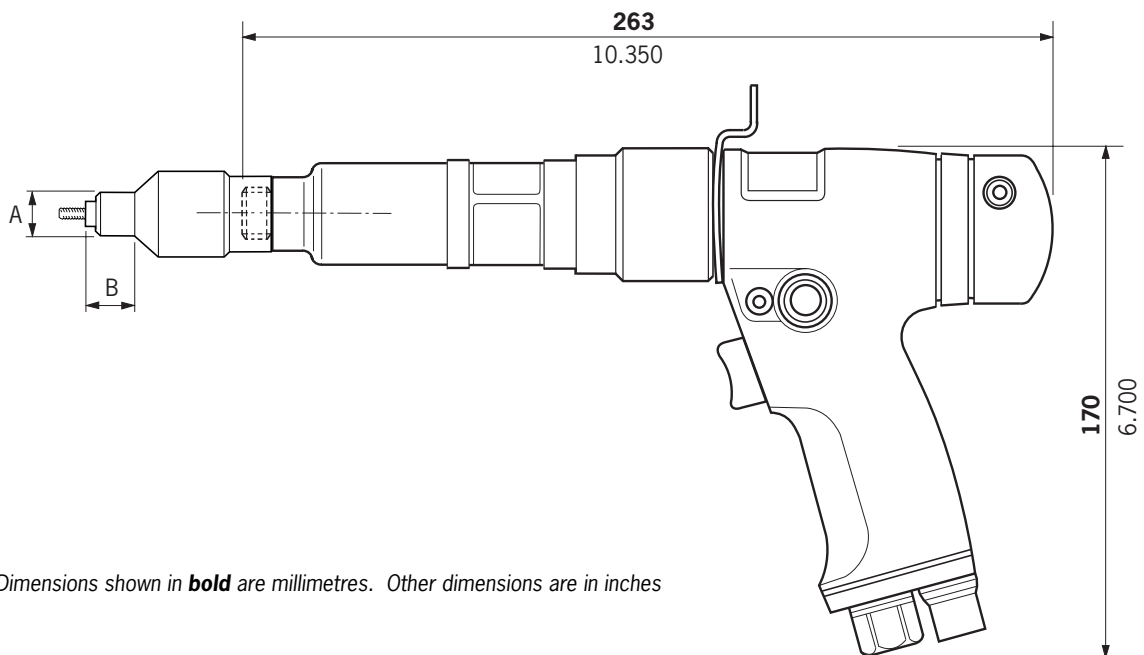

Dimensions shown in **bold** are millimetres. Other dimensions are in inches

# Intent of Use

## Tool Selection

74110 TOOL SELECTION									
INSERT NAME & SERIES	Ø	TORQUE SETTING (lbf ins)	UNSET CLUTCH PART N°	NOSE (see drawing opposite for A & B)				NOSE ASSY PART N°	COMPLETE TOOL PART N°
				A (mm)	B (mm)	A (in)	B (in)		
<b>STANDARD NUTSERTS (9500) (9538)</b>	3/16 BSW	20 - 25	84100-15000	13	12	1/2	15/32	07556-09816	74110-00016
	1/4 BSW	25 - 30	84100-15000	13	15	1/2	19/32	07566-09818	74110-00018
	5/16 BSW	40 - 45	84110-15000	14	14	9/16	9/16	07443-09810	74110-00010
	3/8 BSW	50 - 55	84110-15000	16	10	5/8	13/32	07443-09812	74110-00012
	1/4 BSW	25 - 30	84100-15000	13	15	1/2	19/32	07556-09828	74110-00028
	5/16 BSW	40 - 45	84110-15000	14	14	9/16	9/16	07443-09820	74110-00020
	3/8 BSW	50 - 55	84110-15000	16	10	5/8	13/32	07443-09822	74110-00022
	4 UNC	5 - 7	84100-15020	13	12	1/2	15/32	07556-09854	74110-00054
	6 UNC	9 - 11	84100-15010	13	12	1/2	15/32	07556-09856	74110-00056
	8 UNC	13 - 15	84100-15010	13	10	1/2	13/32	07556-09858	74110-00058
	10 UNC	20 - 25	84100-15000	13	12	1/2	15/32	07556-09850	74110-00050
	6 UNF	9 - 11	84100-15010	13	12	1/2	15/32	07556-09876	74110-00076
	8 UNF	13 - 15	84100-15010	13	10	1/2	13/32	07556-09878	74110-00078
	10 UNF	20 - 25	84100-15000	13	12	1/2	15/32	07556-09870	74110-00070
	1/4 UNC	25 - 30	84100-15000	13	15	1/2	19/32	07566-09848	74110-00048
	5/16 UNC	40 - 45	84110-15000	14	14	9/16	9/16	07443-09840	74110-00040
	3/8 UNC	50 - 55	84110-15000	16	10	5/8	13/32	07443-09842	74110-00042
	1/4 UNF	25 - 30	84100-15000	13	15	1/2	19/32	07556-09868	74110-00068
	5/16 UNF	40 - 45	84110-15000	14	14	9/16	9/16	07443-09860	74110-00060
	3/8 UNF	50 - 55	84110-15000	16	10	5/8	13/32	07443-09862	74110-00062
	6 BA	5 - 7	84100-15020	13	15	1/2	19/32	07556-09836	74110-00036
	4 BA	9 - 11	84100-15010	13	12	1/2	15/32	07556-09834	74110-00034
	2 BA	20 - 25	84100-15000	13	12	1/2	15/32	07556-09832	74110-00032
	0 BA	25 - 30	84100-15000	13	12	1/2	15/32	07556-09830	74110-00030
	M3	5 - 7	84100-15020	13	12	1/2	15/32	07556-09883	74110-00083
	M4	13 - 15	84100-15010	13	10	1/2	13/32	07556-09884	74110-00084
M5	20 - 25	84100-15000	13	12	1/2	15/32	07556-09885	74110-00085	
M6	25 - 30	84100-15000	13	15	1/2	19/32	07556-09886	74110-00086	
M8	40 - 45	84110-15000	14	14	9/16	9/16	07443-09888	74110-00088	
M10	50 - 55	84110-15000	16	12	5/8	15/32	07443-09880	74110-00080	
<b>L/F THIN SHEET NUTSERT® (9698)</b>	M4	16 - 18	84100-15010	13	10	1/2	13/32	07556-09184	74110-04084
	M5	30 - 35	84110-15000	13	12	1/2	15/32	07556-09185	74110-04085
	M6	35 - 40	84110-15000	13	15	1/2	19/32	07556-09186	74110-04086
<b>HEXSERT® (9688)</b>	M4	16 - 18	84110-15010	13	12	1/2	15/32	07556-09284	74110-06084
	M5	30 - 35	84110-15000	13	12	1/2	15/32	07556-09285	74110-06085
	M6	40 - 45	84110-15000	16	14	5/8	9/16	07556-09286	74110-06086
	M8	50 - 55	84110-15000	16	15	5/8	19/32	07443-09288	74110-06088
<b>NUTSERT® SQ (GK08)</b>	M5	30 - 35	84110-15000	10	13	13/32	1/2	07528-07085	74110-07085
	M6	40 - 45	84110-15000	13	15	1/2	19/32	07566-09186	74110-04086

The pneumatic 74110 type tool is designed to place Avdel® threaded inserts at high speed making it ideal for batch or flow-line assembly in a wide variety of applications throughout all industries.

Use the selection table opposite to select a complete tool which will be fitted with the correct nose assembly for the threaded insert selected. 'A' and 'B' dimensions will help you assess the accessibility of your application.

It is also possible to order the base tool only (part number 74110-12000). For details of Nose Assemblies see pages 11 and 12.

# Intent of Use

## Tool Selection

74110 TOOL SELECTION									
INSERT NAME & SERIES	Ø	TORQUE SETTING (lbf ins)	UNSET CLUTCH PART N°	NOSE (see drawing opposite for A & B)				COMPLETE TOOL PART N°	
				A (mm)	B (mm)	A (in)	B (in)		NOSE ASSY PART N°
<b>THIN SHEET NUTSERT® (9650)</b>	3/16 BSW	30 - 35	84110-15000	13	10	1/2	13/32	07556-09916	74110-01016
	1/4 BSW	35 - 40	84110-15000	13	13 1/2	1/2	17/32	07566-09918	74110-01018
	5/16 BSW	50 - 55	84110-15000	14	14	9/16	9/16	07443-09910	74110-01010
	1/4 BSF	35 - 40	84110-15000	13	13 1/2	1/2	17/32	07556-09928	74110-01028
	5/16 BSF	50 - 55	84110-15000	14	14	9/16	9/16	07443-09920	74110-01020
	4 UNC	7 - 9	84100-15020	13	11	1/2	7/16	07556-09954	74110-01054
	6 UNC	16 - 18	84100-15010	13	11	1/2	7/16	07556-09956	74110-01056
	8 UNC	16 - 18	84100-15010	13	12	1/2	15/32	07556-09958	74110-01058
	10 UNC	30 - 35	84110-15000	13	10	1/2	13/32	07556-09950	74110-01050
	4 UNF	7 - 9	84100-15020	13	11	1/2	7/16	07556-09974	74110-01074
	6 UNF	16 - 18	84100-15010	13	11	1/2	7/16	07556-09976	74110-01076
	8 UNF	16 - 18	84100-15010	13	12	1/2	15/32	07556-09978	74110-01078
	10 UNF	30 - 35	84110-15000	13	10	1/2	13/32	07556-09970	74110-01070
	1/4 UNC	35 - 40	84110-15000	13	13 1/2	1/2	17/32	07556-09948	74110-01048
	5/16 UNC	50 - 55	84110-15000	14	14	9/16	9/16	07443-09940	74110-01040
	1/4 UNF	35 - 40	84110-15000	13	13 1/2	1/2	17/32	07556-09968	74110-01068
	5/16 UNF	50 - 55	84110-15000	14	14	9/16	9/16	07443-09960	74110-01060
	6 BA	7 - 9	84100-15020	13	13 1/2	1/2	17/32	07556-09936	74110-01036
	4 BA	16 - 18	84100-15010	13	11	1/2	7/16	07556-09934	74110-01034
	2 BA	30 - 35	84110-15000	13	17	1/2	21/32	07556-09932	74110-01032
	0 BA	35 - 40	84110-15000	13	11	1/2	7/16	07556-09930	74110-01030
	M3	7 - 9	84100-15020	13	11	1/2	7/16	07556-09983	74110-01083
	M4	16 - 18	84100-15010	13	11	1/2	7/16	07556-09984	74110-01084
	M5	30 - 35	84110-15000	13	10	1/2	13/32	07556-09985	74110-01085
M6	35 - 40	84110-15000	13	13 1/2	1/2	17/32	07556-09986	74110-01086	
M8	50 - 55	84110-15000	14	14	9/16	9/16	07443-09988	74110-01088	
<b>SUPERSERT® (FB00)</b>	8 UNC	16 - 18	84100-15010	13	10	1/2	13/32	07552-09558	74110-02058
	10 UNC	30 - 35	84110-15000	13	12	1/2	15/32	07552-09550	74110-02050
	8 UNF	16 - 18	84100-15010	13	10	1/2	13/32	07552-09578	74110-02078
	10 UNF	30 - 35	84110-15000	13	12	1/2	15/32	07552-09570	74110-02070
	1/4 UNC	45 - 50	84110-15000	13	15	1/2	19/32	07552-09548	74110-02048
	1/4 UNF	45 - 50	84110-15000	13	15	1/2	19/32	07552-09568	74110-02068
	M3	16 - 18	84100-15010	13	19	1/2	3/4	07552-09583	74110-02083
	M4	16 - 18	84100-15010	13	10	1/2	13/32	07552-09584	74110-02084
	M5	30 - 35	84110-15000	13	11	1/2	7/16	07552-09585	74110-02085
	M6	45 - 50	84110-15000	13	15	1/2	19/32	07552-09586	74110-02086
<b>LGE FLANGE HEXSERT® (9498)</b>	M4	16 - 18	84100-15010	13	10	1/2	13/32	07556-09184	74110-04084
	M5	30 - 35	84110-15000	13	10	1/2	13/32	07557-09285	74110-03085
	M6	35 - 40	84110-15000	14	12	9/16	15/32	07556-09186	74110-04086

# Putting into Service

## Air Supply

All tools are operated with compressed air at an optimum pressure of 5.5 bar. We recommend the use of pressure regulators and automatic oiling/filtering systems on the main air supply. These should be fitted within 3 metres of the tool (see diagram below) to ensure maximum tool life and minimum tool maintenance.

Air supply hoses should have a minimum working effective pressure rating of 150% of the maximum pressure produced in the system or 10 bar, whichever is the highest. Air hoses should be oil resistant, have an abrasion resistant exterior and should be armoured where operating conditions may result in hoses being damaged. All air hoses MUST have a minimum bore diameter of 6.4 millimetres or 1/4 inch.

Read servicing daily details page 13.

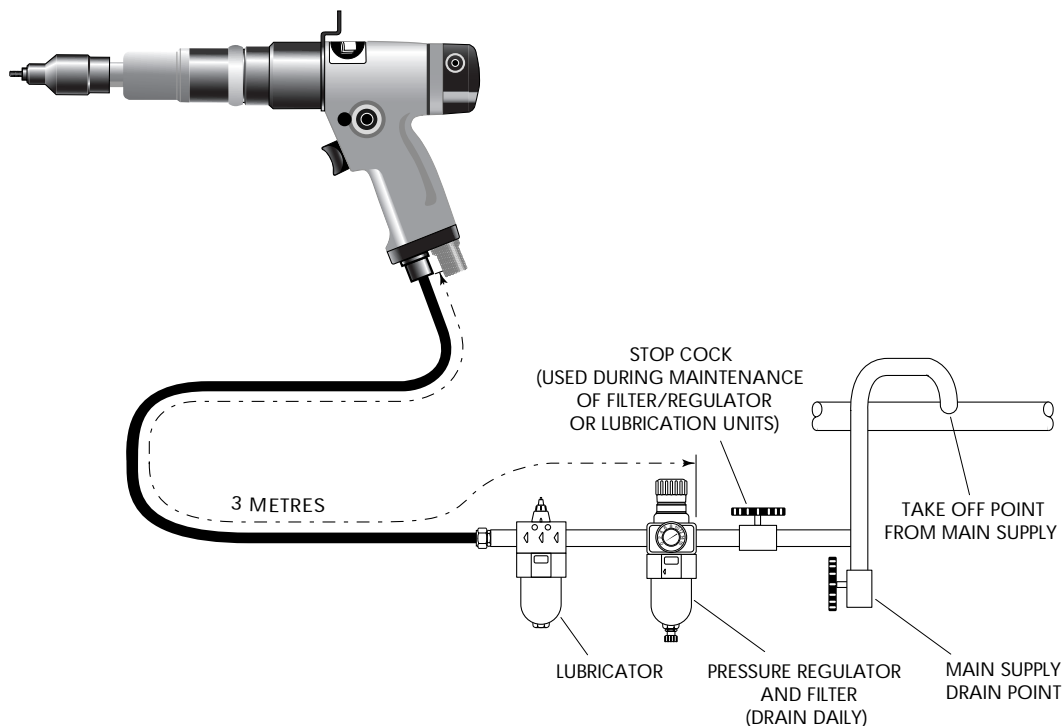

## Operating Procedure

### IMPORTANT

When placing Standard Nutserts, lubricate the drive screw of the tool every 25 placings. This is best achieved by wiping the drive screw with a sponge soaked with STP Lubricant part number 07992-00013.

#### OPTION 1

- Ensure that the correct nose equipment is fitted.
- Connect the tool to the air supply.
- Place the insert into the prepared hole of the application.
- Locate the drive screw of the tool into the insert.
- Operate the lever. The drive screw will screw into and collapse the insert, then automatically reverse out.

#### OPTION 2

- Ensure that the correct nose equipment is fitted.
- Connect the tool to the air supply.
- Screw the insert lip first onto the drive screw of the tool.
- With the insert on the tool, locate it into the prepared hole of the application.
- Operate the lever. The drive screw will screw into and collapse the insert, then automatically reverse out.

# Putting into Service

## Clutch Adjustment

If you have ordered a complete tool the clutch will be set for the specified insert.

When purchased as a spare part, the clutch is supplied unset.

Correct clutch setting is necessary to ensure optimum deformation of the insert. If the deformation is insufficient (clutch torque too low) the insert will rotate in the application. If the deformation is excessive (clutch torque too high) thread distortion will occur and extensive wear on the drivescrew, may lead to fracture.

For details on how to adjust the clutch refer to maintenance instructions referring to the clutch on page 15.

## Accessories

---

Two different accessories are available to make the connection to your air supply:

**Hose Connector**  
part n° 07005-00276

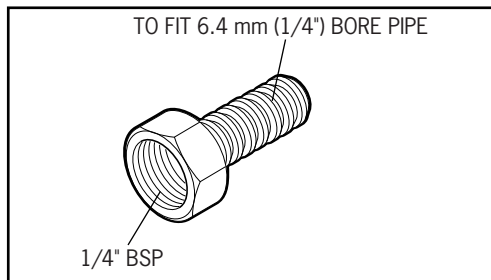

**Hose Assembly**  
part n° 07008-000324

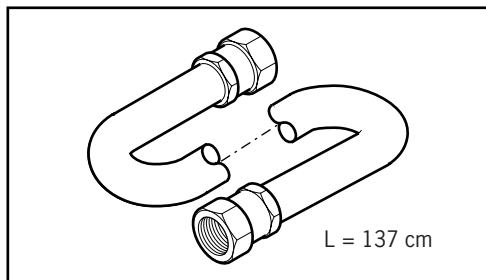

# Nose Assemblies

Nose assemblies are specifically designed for each size and type of insert. If you have purchased a complete tool, it will already be fitted with the correct nose assembly for your insert.

It is essential that the correct nose assembly is fitted prior to operating the tool. By knowing your original complete tool part number or the details of the insert to be placed, you will be able to order a new complete nose assembly using the selection table pages 11 and 12.

## Fitting Instructions

### IMPORTANT

The air supply must be disconnected when fitting or removing nose assemblies unless specifically instructed otherwise.

Before fitting the nose equipment, ensure the clutch on the tool is set to the correct torque for the insert being placed. (Torque values are on page 7.)

- Where applicable, insert sleeve **8** and thrust spring **9** into nose housing **2**.
- Coat thrust washers **3** and thrust bearing **4** with high pressure grease (eg. Shell Alvania E.P.I.) and locate them in the order shown below into the nose housing **2**.
- Where applicable, fit spacer **5** through thrust washers and thrust bearings.
- Insert drive screw **1** through the above assembly.
- Fit drive shaft **6** into the hexagon hole in the drive screw head.
- Insert stop **11** and spring **10** into the front of the base tool.
- Screw adaptor **7** into clutch housing of the base tool (left hand thread).
- Offer up the nose assembly to the adaptor. It will be necessary to rotate the drive screw by hand to line up the hexagon on the drive shaft **6** with the hexagonal hole in the front jaw of the base tool.
- Screw the nose housing **2** onto the adaptor **7** and tighten with a spanner (left hand thread).

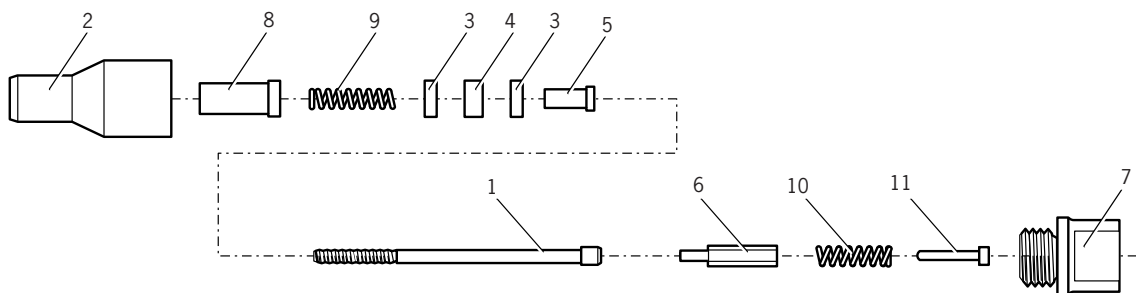

## Servicing Instructions

Nose assemblies should be serviced at weekly intervals.

- Remove the complete nose assembly using the reverse procedure to the 'Fitting Instructions'.
- Any worn or damaged part should be replaced.
- Particularly check wear on drivescrew, thrust washers and thrust bearing.
- Lubricate thrust washers and thrust bearings with high pressure grease (eg Shell Alvania E.P.I.)
- Check springs are not distorted.
- Assemble according to fitting instructions.

# Nose Assemblies

## Nose Assembly Components

The table below lists all nose assemblies available. Each nose assembly represents a unique assembly of components which can be ordered individually. Components numbers refer to the text and illustration opposite. We recommend some stock as items will need regular replacement. Read the nose assemblies servicing instructions opposite carefully. All nose assemblies also include spring 10 part number 07430-08202 and stop 11 part number 07430-08203.

NOSE ASSY	1	2	3	4	5	6	7	8	9
07443-09288	07001-00084	07522-08988	07007-00081	07007-00078	07443-03110	07430-01808	07443-08002	07522-08902	07154-03092
07443-09810	07001-00076	07443-06110	07007-00081	07007-00078	07443-03110	07430-01110	07443-08002	-	-
07443-09812	07001-00099	07443-06112	07007-00081	07007-00078	-	07430-01112	07443-08002	-	-
07443-09820	07001-00077	07443-06110	07007-00081	07007-00078	07443-03110	07430-01110	07443-08002	-	-
07443-09822	07001-00098	07443-06112	07007-00081	07007-00078	-	07430-01112	07443-08002	-	-
07443-09840	07001-00078	07443-06110	07007-00081	07007-00078	07443-03110	07430-01110	07443-08002	-	-
07443-09842	07001-00106	07443-06112	07007-00081	07007-00078	-	07430-01112	07443-08002	-	-
07443-09860	07001-00079	07443-06110	07007-00081	07007-00078	07443-03110	07430-01110	07443-08002	-	-
07443-09862	07001-00105	07443-06112	07007-00081	07007-00078	-	07430-01112	07443-08002	-	-
07443-09880	07001-00100	07443-06810	07007-00082	07007-00079	-	07430-01810	07443-08003	-	-
07443-09888	07001-00084	07443-06110	07007-00081	07007-00078	07443-03110	07430-01808	07443-08002	-	-
07443-09910	07001-00076	07443-08805	07007-00081	07007-00078	07443-03110	07430-01110	07443-08002	-	-
07443-09920	07001-00077	07443-08805	07007-00081	07007-00078	07443-03110	07430-01110	07443-08002	-	-
07443-09940	07001-00078	07443-08805	07007-00081	07007-00078	07443-03110	07430-01110	07443-08002	-	-
07443-09960	07001-00079	07443-08805	07007-00081	07007-00078	07443-03110	07430-01110	07443-08002	-	-
07443-09988	07001-00084	07443-08805	07007-00081	07007-00078	07443-03110	07430-01808	07443-08002	-	-
07528-07085	07001-00256	07557-08985	07007-00080	07007-00077	07521-08808	07521-08806	07443-08001	-	-
07552-09548	07001-00336	07552-07704	07007-00080	07007-00077	-	07522-08801	07443-08001	-	-
07552-09550	07001-00300	07552-07706	07007-00080	07007-00077	07521-08808	07521-08803	07443-08001	-	-
07552-09568	07001-00110	07552-07704	07007-00080	07007-00077	-	07522-08801	07443-08001	-	-
07552-09570	07001-00301	07552-07706	07007-00080	07007-00077	07521-08808	07521-08803	07443-08001	-	-
07552-09578	07001-00319	07552-07701	07007-00080	07007-00077	07521-08809	07521-08804	07443-08001	-	-
07552-09583	07001-00325	07552-07709	07007-00080	07007-00077	07520-08803	07520-08802	07443-08001	-	-
07552-09584	07001-00326	07552-07705	07007-00080	07007-00077	07521-08810	07521-08805	07443-08001	-	-
07552-09585	07001-00256	07552-07702	07007-00080	07007-00077	07521-08808	07521-08806	07443-08001	-	-
07552-09586	07001-00337	07552-07703	07007-00080	07007-00077	-	07522-08802	07443-08001	-	-
07552-09588	07001-00084	07552-07710	07007-00081	07007-00078	07443-03110	07430-01808	07443-08002	-	-
07556-09184	07001-00326	07552-06804	07007-00080	07007-00077	07521-08810	07521-08805	07443-08001	07552-08804	07440-08002
07556-09185	07001-00256	07552-06805	07007-00080	07007-00077	07521-08808	07521-08806	07443-08001	07552-08805	07440-08002
07556-09186	07001-00337	07552-06806	07007-00080	07007-00077	-	07522-08802	07443-08001	07552-08806	07150-00403
07556-09284	07001-00326	07521-08984	07007-00080	07007-00077	07521-08810	07521-08805	07443-08001	07521-08901	07440-08002
07556-09285	07001-00256	07521-08985	07007-00080	07007-00077	07521-08808	07521-08806	07443-08001	07521-08902	07440-08002
07556-09286	07001-00337	07522-08986	07007-00080	07007-00077	-	07522-08802	07443-08001	07522-08901	07150-00504
07556-09816	07001-00320	07440-06805	07007-00080	07007-00077	07521-08808	07521-08803	07443-08001	-	-
07556-09818	07001-00334	07443-06108	07007-00080	07007-00077	-	07522-08801	07443-08001	-	-
07556-09828	07001-00333	07443-06108	07007-00080	07007-00077	-	07522-08801	07443-08001	-	-
07556-09830	07001-00335	07443-06108	07007-00080	07007-00077	07521-08801	07522-08801	07443-08001	-	-
07556-09832	07001-00321	07440-06805	07007-00080	07007-00077	07521-08808	07521-08803	07443-08001	-	-
07556-09834	07001-00315	07440-06304	07007-00080	07007-00077	07521-08807	07521-08802	07443-08001	-	-
07556-09836	07001-00276	07440-06306	07007-00080	07007-00077	07520-08803	07520-08801	07443-08001	-	-
07556-09848	07001-00336	07443-06108	07007-00080	07007-00077	-	07522-08801	07443-08001	-	-
07556-09850	07001-00300	07440-06805	07007-00080	07007-00077	07521-08808	07521-08803	07443-08001	-	-
07556-09854	07001-00313	07440-06306	07007-00080	07007-00077	07520-08803	07520-08801	07443-08001	-	-
07556-09856	07001-00316	07440-06304	07007-00080	07007-00077	07521-08807	07521-08802	07443-08001	-	-
07556-09858	07001-00318	07440-06508	07007-00080	07007-00077	07521-08809	07521-08804	07443-08001	-	-
07556-09868	07001-00110	07440-06108	07007-00080	07007-00077	-	07522-08801	07443-08001	-	-
07556-09870	07001-00301	07440-06805	07007-00080	07007-00077	07521-08808	07521-08803	07443-08001	-	-
07556-09876	07001-00317	07440-06304	07007-00080	07007-00077	07521-08807	07521-08802	07443-08001	-	-
07556-09878	07001-00319	07440-06508	07007-00080	07007-00077	07521-08809	07521-08804	07443-08001	-	-
07556-09883	07001-00325	07440-06308	07007-00080	07007-00077	07520-08803	07520-08802	07443-08001	-	-
07556-09884	07001-00326	07440-06508	07007-00080	07007-00077	07521-08810	07521-08805	07443-08001	-	-
07556-09885	07001-00256	07440-06805	07007-00080	07007-00077	07521-08808	07521-08806	07443-08001	-	-
07556-09886	07001-00337	07443-06108	07007-00080	07007-00077	-	07522-08802	07443-08001	-	-

Nose assembly table continued overleaf

# Nose Assemblies

NOSE ASSY	1	2	3	4	5	6	7	8	9
07556-09916	07001-00320	07440-08805	07007-00080	07007-00077	07521-08808	07521-08803	07443-08001	-	-
07556-09918	07001-00334	07551-08803	07007-00080	07007-00077	-	07522-08801	07443-08001	-	-
07556-09928	07001-00333	07551-08805	07007-00080	07007-00077	-	07522-08801	07443-08001	-	-
07556-09930	07001-00335	07551-08802	07007-00080	07007-00077	-	07522-08801	07443-08001	-	-
07556-09932	07001-00321	07552-08816	07007-00080	07007-00077	07521-08808	07521-08803	07443-08001	-	-
07556-09934	07001-00315	07440-08804	07007-00080	07007-00077	07521-08807	07521-08802	07443-08001	07521-08801	07440-08002
07556-09936	07001-00276	07440-08803	07007-00080	07007-00077	07520-08803	07520-08801	07443-08001	07440-08003	07440-08002
07556-09948	07001-00336	07551-08803	07007-00080	07007-00077	-	07522-08801	07443-08001	-	-
07556-09950	07001-00300	07440-08805	07007-00080	07007-00077	07521-08808	07521-08803	07443-08001	-	-
07556-09954	07001-00313	07440-08803	07007-00080	07007-00077	07520-08803	07521-08801	07443-08001	-	-
07556-09956	07001-00316	07440-08804	07007-00080	07007-00077	07521-08807	07521-08802	07443-08001	-	-
07556-09958	07001-00318	07440-08808	07007-00080	07007-00077	07521-08809	07521-08804	07443-08001	-	-
07556-09968	07001-00110	07551-08803	07007-00080	07007-00077	-	07522-08801	07443-08001	-	-
07556-09970	07001-00301	07440-08805	07007-00080	07007-00077	07521-08808	07521-08803	07443-08001	-	-
07556-09974	07001-00314	07440-08803	07007-00080	07007-00077	07520-08803	07520-08801	07443-08001	-	-
07556-09976	07001-00317	07440-08804	07007-00080	07007-00077	07521-08807	07521-08802	07443-08001	-	-
07556-09978	07001-00319	07440-08808	07007-00080	07007-00077	07521-08809	07521-08804	07443-08001	-	-
07556-09983	07001-00325	07440-08803	07007-00080	07007-00077	07520-08803	07520-08802	07443-08001	-	-
07556-09984	07001-00326	07552-08817	07007-00080	07007-00077	07521-08810	07521-08805	07443-08001	-	-
07556-09985	07001-00256	07440-08805	07007-00080	07007-00077	07521-08808	07521-08806	07443-08001	-	-
07556-09986	07001-00337	07551-08802	07007-00080	07007-00077	-	07522-08802	07443-08001	-	-
07557-09285	07001-00256	07557-08901	07007-00080	07007-00077	07521-08808	07521-08806	07443-08001	07557-08902	07440-08002

# Servicing the Tool

Regular servicing should be carried out and a comprehensive inspection performed annually or every 200000 cycles, whichever is soonest.

## **I M P O R T A N T**

**The employer is responsible for ensuring that tool maintenance instructions are given to the appropriate personnel. The operator should not be involved in maintenance or repair of the tool unless properly trained.**

## **Daily Servicing**

---

- Daily, before use or when first putting the tool into service, pour a few drops of clean, light lubricating oil into the air inlet of the tool if no lubricator is fitted on air supply. If the tool is in continuous use, the air hose should be disconnected from the main air supply and the tool lubricated every two to three hours.
- Check for air leaks. If damaged, hoses and couplings should be replaced by new items.
- If there is no filter on the pressure regulator, bleed the air line to clear it of accumulated dirt or water before connecting the air hose to the tool. If there is a filter fitted, drain it.
- Check that the nose assembly is correct.
- Inspect the drivescrew in the nose assembly for wear or damage. If there is any, renew.

## **Weekly Servicing**

---

- Fully dismantle and service the nose assembly (see instructions page 10).
- Lubricate the clutch spring with high pressure grease (eg. Shell Alvania EPI).
- Check the clutch torque setting (see clutch adjustment procedure page 15).
- Check for air leaks in the air supply hose and fittings.

# Safety Data (Grease)

## **Moly-Lithium Grease EP 3753 Safety Data**

---

*For lubricating internal tool parts other than those described previously, use Moly-Lithium Grease EP3753 (part number 07992-00020)*

### **First Aid**

#### **SKIN:**

As the grease is completely water resistant it is best removed with an approved emulsifying skin cleaner.

#### **INGESTION:**

Ensure the individual drinks 30ml Milk of Magnesia, preferably in a cup of milk.

#### **EYES:**

Irritant but not harmful. Irrigate with water and seek medical attention.

### **Fire**

FLASH POINT: Above 220°C.

Not classified as flammable.

Suitable extinguishing media: CO<sub>2</sub>, Halon or water spray if applied by an experienced operator.

### **Environment**

Scrape up for burning or disposal on approved site.

### **Handling**

Use barrier cream or oil resistant gloves.

### **Storage**

Away from heat and oxidising agent.

# Maintenance

## TO RESET CLUTCH TORQUE

- Ensure the correct coloured Clutch Spring is selected in order to obtain the required torque.
- With a minimum gap set between Adjusting Ring **71** and Circlip **72** and using the Clutch Key, rotate **71** (anti clockwise) until the required number of full turns have been completed to obtain the required Torque as shown in the Table below.
- White numbers on black background indicate Number of turns. Black numbers on white background indicate expected Torque in lbf ins.

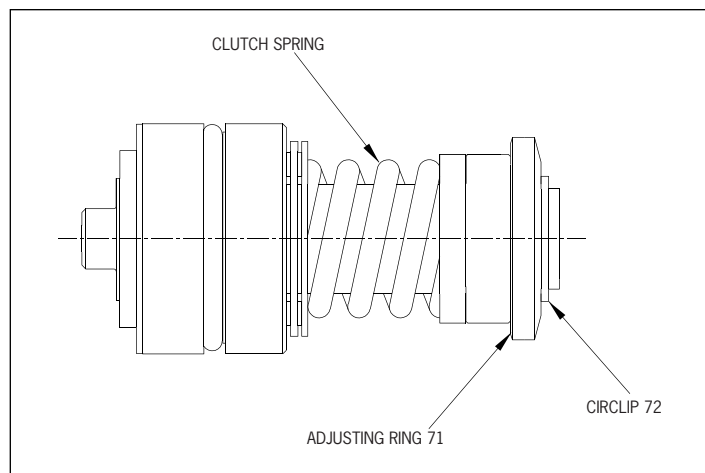

			<b>74110 CLUTCH DETAILS</b>																		
UNSET CLUTCH PART N°	SPRING PART N°	SPRING COLOUR	N° OF TURNS/lb f ins																		
			1	2	3	4	5	6	7	8	9	10	11	12	13	14	15	16	17	18	
84110-15000	84110-15001	BLUE	30	33	38	45	50	56	61	64	-	-	-	-	-	-	-	-	-		
84100-15000	84100-15001	GREEN	-	20	23	24	25	28	30	32	32	36	40	40	42	-	-	-	-		
84100-15010	84100-15011	RED	-	9	10	10	14	15	15	15	16	17	18	19	20	-	-	-	-		
84100-15020	84100-15021	YELLOW	-	-	-	-	-	-	-	-	-	-	-	-	-	2	4	5	7	7	8

# Maintenance

## Clutch Assembly

### DISMANTLING

Item numbers in **Bold** refer to illustration.

- Unscrew Clutch Case 103 (L/H thread ).
- Remove Bit Holder and Spring Washers.
- Remove Clutch Assy **110**.
- Using the supplied Clutch Key rotate Adjusting Ring **71** till a minimum gap between **71** and Circlip **72** is obtained.
- Using suitable Circlip Pliers remove **72**.
- Remove Adjusting Ring **71**, and Items **70, 73, 84**.
- Remove Clutch Spring **56, 57** or **69**.
- Assemble in reverse order, ensuring that Clutch Case 103 is tightened to the correct Torque (6.8Nm) as shown on assembly drawing 74110-12000 (s).

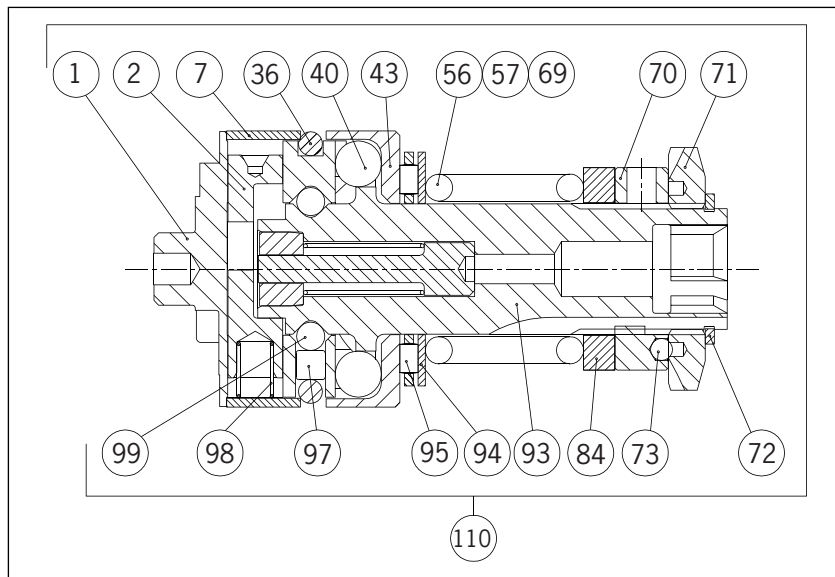

CLUTCH ASSEMBLY PARTS LIST					
ITEM	SUPPLIER PART No.	DESCRIPTION	AVDEL PART No.	QTY	REC SPARES
1	296693	CAM CLUTCH	84100-12074	1	
2	296623	LATCH PIN	84100-12075	1	
7	296683	RETAINING SLEEVE	84100-12076	1	
36	37233	O RING	84100-12077	1	2
40	81243	BALL (5mm)	84100-12078	6	6
43	296673	CUP BALL	84100-12079	1	
56	68448	SPRING (GREEN)	84100-15001	1	
57	71378	SPRING (YELLOW)	84110-15021	1	
69	73318	SPRING (BLUE)	84100-15000	1	
70	76013	LOCKWASHER	84100-12084	1	
71	76003	ADJUSTING RING	84100-12085	1	
72	218453	CIRCLIP	84100-12086	1	1
73	72228	BALL	84100-12087	3	2
84	389833	SPACER	84100-12088	1	
93	296983	SPINDLE CLUTCH ASSy	84100-12091	1	
94	297973	THRUST WASHER	84100-12090	1	
95	297963	THRUST RACE	84100-12089	1	1
97	18243	ROLLER	84100-12092	1	2
98	307123	SPRING	84100-12093	1	
99	72408	STEEL BALL	84100-12094	14	14
110	389813	COMPLETE CLUTCH	84110-12078	1	

# Maintenance

## Gearbox Assembly

Item numbers in **Bold** refer to illustration.

- Thoroughly clean all components.
- Assemble Washers **61** and **62**, Distance Collar **92** and Bearing **67**, onto Final Planet Carrier **68**, retain with Circlip **91**.
- Apply recommended grease to all components and assemble into Gear Ring **64**.
- With Key **59** in position slide Gear Case 60 over Bearing **67**, and insert into Pistol Grip Body.
- Tighten 60 to stated torque value.
- Dismantle in reverse order.

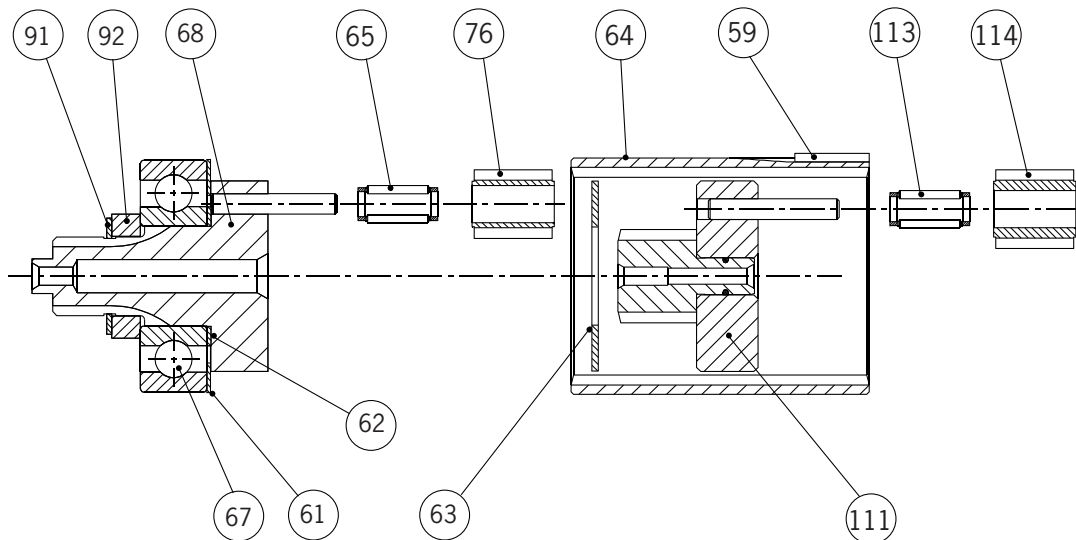

GEARBOX PARTS LIST					
ITEM	SUPPLIER PART No.	DESCRIPTION	AVDEL PART No.	QTY	REC SPARES
59	251993	SQUARE KEY	84110-12048	1	
61	500813	WASHER	84110-12050	1	
62	500763	WASHER	84110-12051	1	
63	251583	WASHER	84110-12052	1	
64	251473	GEAR RING	84110-12053	1	
65	251663	CAGED NEEDLE ASSy	84110-12054	3	3
67	251983	BEARING	84100-12015	1	1
68	272783	FINAL PLANET CARRIER	84110-12056	1	
91	42353	CIRCLIP	84110-12013	1	1
92	157513	DISTANCE COLLAR	84110-12073	1	
111	251953	PLANET CARRIER SA	84110-12079	1	
113	251673	CAGED NEEDLE ASSy	84110-12080	3	3
114	251403	PLANET WHEEL	84110-12081	3	

# Maintenance

## Motor Assembly

Item numbers in **Bold** refer to illustration.

- Fit Rear Bearing Plate **48** over rear spigot of Rotor **50**, applying pressure to inner race of Bearing **47** press to give gap shown in illustration.
- Fit Rotor Blades **51** (5 off) to Rotor **50**, slide Cylinder **49** over the assembly.
- Fit Front Bearing Plate **52** over front spigot of **50**. Supporting rear spigot of **50** apply pressure to the inner race of Bearing **54**, press onto front spigot.
- Fit Rear Bearing Housing **46** to rear of assembly.
- Fit Front Bearing Housing **53** to front of assembly.

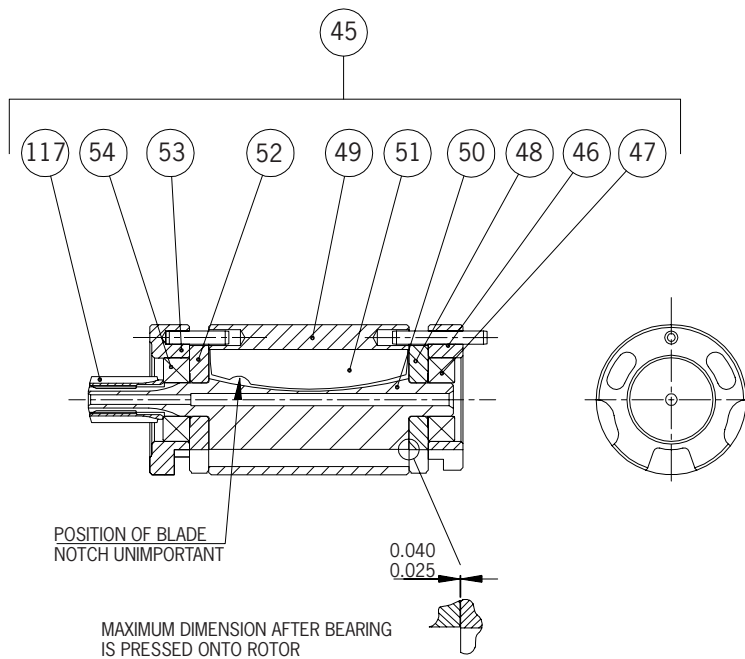

MOTOR ASSEMBLY PARTS LIST					
ITEM	SUPPLIER PART No.	DESCRIPTION	AVDEL PART No.	QTY	REC SPARES
45	305743	MOTOR COMPLETE	84110-12036	1	
46	256713	REAR BEARING HOUSING	84110-12037	1	
47	500693	BEARING	84110-12038	1	2
48	256723	REAR BEARING PLATE	84110-12039	1	1
49	500203	CYLINDER	84110-12040	1	
50	251763	ROTOR	84110-12041	1	
51	305233	ROTOR BLADES	84110-12042	5	10
52	256733	FRONT BEARING PLATE	84110-12043	1	1
53	256743	FRONT BEARING HOUSING	84110-12044	1	
54	64368	BEARING	84110-12045	1	2
117	251393	ROTOR PINION	84110-12082	1	

### WARNING

WHEN ASSEMBLING OR SERVICING OIL FREE MOTOR SMOKING IS PROHIBITED. THE ROTOR BLADES CONTAIN P.T.F.E. AND AT TEMPERATURES ABOVE 300° INHALING THE RESULTANT VAPOUR MAY CAUSE A TEMPORARY ALLERGIC REACTION. CARE SHOULD BE TAKEN WHEN BLOWING OUT P.T.F.E. RESIDUE FROM SINTERED SILENCER. ALWAYS WASH HANDS BEFORE TOUCHING CIGARETTES, PIPES, FOOD ETC.

# Maintenance

## Setting the Push Rod

- Apply shims and spacers to obtain a maximum axial clutch movement of 0.13mm

*Note: Shims must be adjacent to face of Bit Holder*

- Apply pressure in direction of arrow (A)
- Apply pressure to Push Rod (B) until a hard stop is felt. Measure dimension X.
- Obtain the specified dimension by grinding the Push Rod (B).

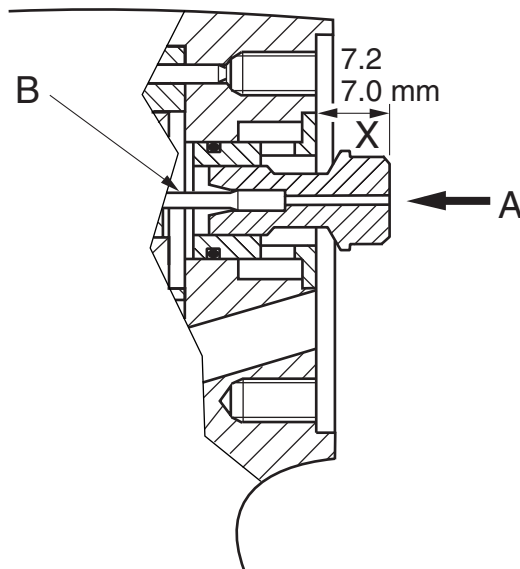

# General Assembly of Base Tool 74110-12000(s)

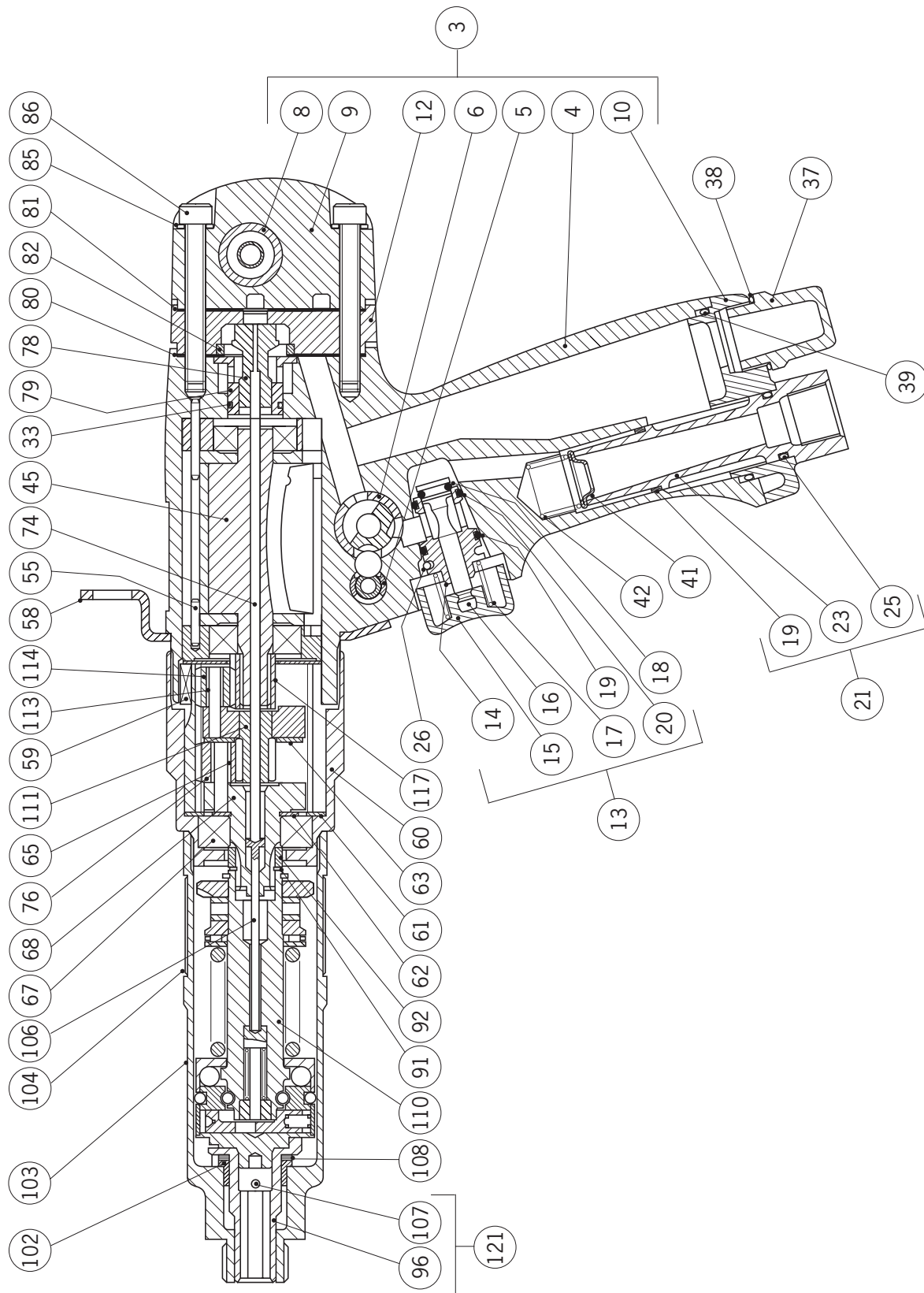

# Parts List for 74110-12000(s)

74110-12000 PARTS LIST									
ITEM	PART N°	DESCRIPTION	QTY	REC. SPARES	ITEM	PART N°	DESCRIPTION	QTY	REC. SPARES
1	84100-12074	CAM CLUTCH	1		31	84110-12025	SPRING	1	
2	84100-12075	LATCH PIN	1		32	84110-12026	LOCKING SPINDLE	1	
3	84110-12001	PISTOL GRIP AND BUSH SA	1		33	84110-12027	'O' RING	3	
4	84110-12002		PISTOL GRIP BODY	1		34	84110-12028	REVERSE VALVE	1
5	84110-12003	LOCKING BUSH	1		35	84110-12029	RETAINING RING	1	
6	84110-12004	REVERSE VALVE BUSH	1		36	84100-12077	'O' RING	1	2
7	84100-12076	RETAINING SLEEVE	1		37	84110-12030	SILENCER	1	
8	84110-12005	VALVE BUSH	1		38	84110-12031	'O' RING	1	
9	84110-12006	END CAP	1		39	84110-12032	'O' RING	1	
10	84110-12007	EXHAUST CAP	1		40	84100-12078	BALL (5mm)	6	6
11					41	84110-12033	AIR STRAINER	1	
12	84110-12008	EXTENSION PIECE	1		42	84110-12034	SPRING	1	
13	84110-12009	TRIGGER SA	1		43	84100-12079	CUP BALL	1	
14	84110-12010	VALVE BUSH	1		44	84110-12035	'O' RING	1	
15	84110-12011	TRIGGER BUTTON	1		45	84110-12036	MOTOR COMPLETE	1	
16	84110-12012	VALVE SPINDLE	1		46	84110-12037	REAR BEARING HOUSING	1	
17	84110-12013	SPRING	1		47	84110-12038	BEARING	1	2
18	84110-12014	'O' RING	1		48	84110-12039	REAR BEARING PLATE	1	1
19	84110-12015	'O' RING	1		49	84110-12040	CYLINDER	1	
20	84110-12016	'O' RING	1		50	84110-12041	ROTOR	1	
21	84110-12017	AIR INLET BOLT SA	1		51	84110-12042	ROTOR BLADES	5	10
22					52	84110-12043	FRONT BEARING PLATE	1	1
23	84110-12018	AIR INLET BOLT	1		53	84110-12044	FRONT BEARING HOUSING	1	
24					54	84110-12045	BEARING	1	2
25	84110-12019	'O' RING	1		55	84110-12046	SPIROL PIN	1	
26	84110-12020	SPRING PIN	1		56	84100-15001	SPRING (GREEN)	1	
27	84110-12021	'O' RING	1		57	84100-15021	SPRING (YELLOW)	1	
28	84110-12022	'O' RING	1		58	84110-12047	SUSPENSION RING	1	
29	84110-12023	BALL	1		59	84110-12048	SQUARE KEY	1	
30	84110-12024	CAP	1		60	84110-12049	GEAR CASE	1	

# General Assembly of Base Tool 74110-12000(s)

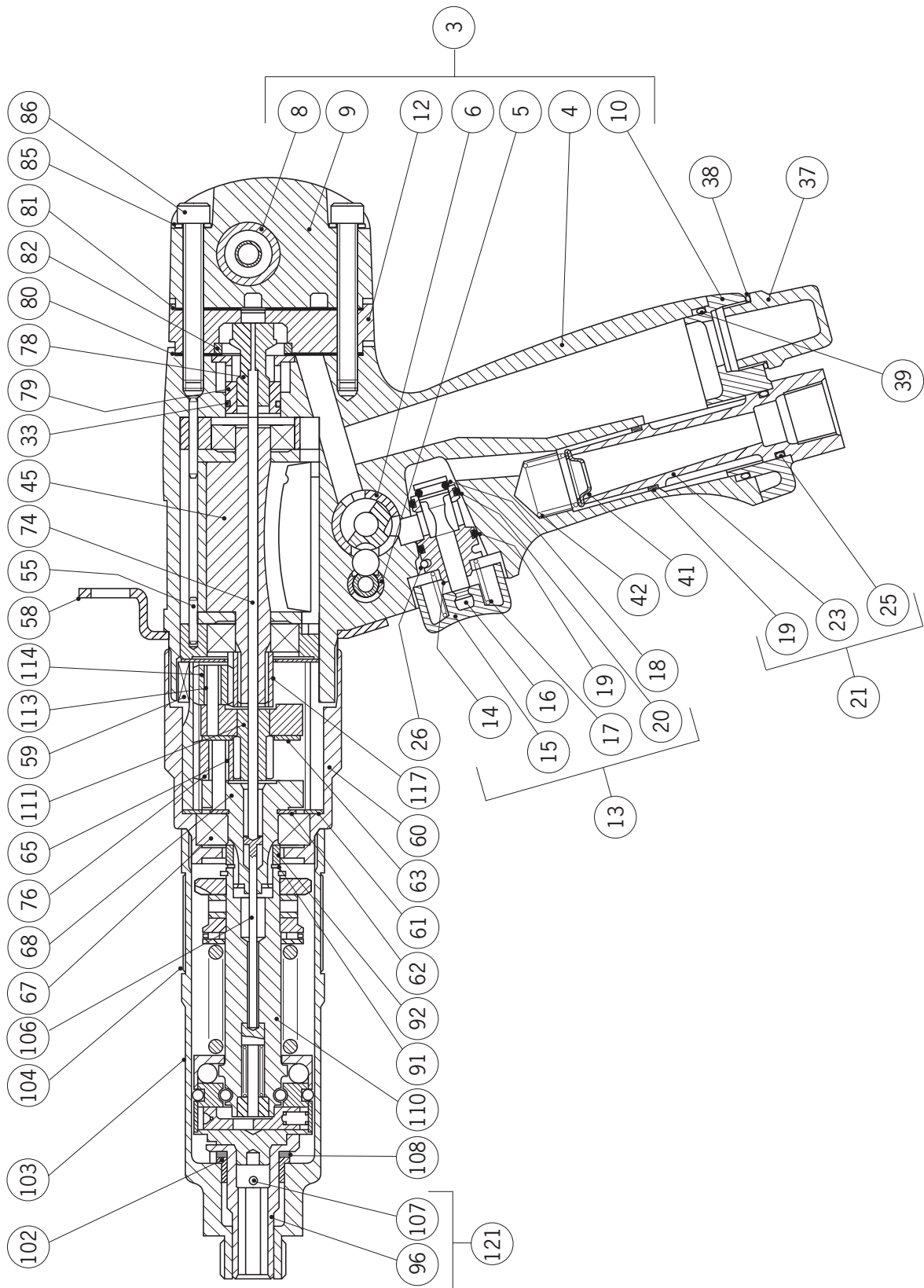

# Parts List for 74110-12000(s)

74110-12000 PARTS LIST									
ITEM	PART N°	DESCRIPTION	QTY	REC. SPARES	ITEM	PART N°	DESCRIPTION	QTY	REC. SPARES
61	84110-12050	WASHER	1		91	84110-12013	CIRCLIP	1	1
62	84110-12051	WASHER	1		92	84110-12073	DISTANCE COLLAR	1	
63	84110-12052	WASHER	1		93	84110-12091	SPINDLE CLUTCH ASSY	1	
64	84110-12053	GEAR RING	1		94	84110-12090	THRUST WASHER	1	
65	84110-12054	CAGED NEEDLE ASSY	3	3	95	84110-12089	THRUST RACE	1	1
66	84110-12055	WASHER	1		96	84110-12001	BIT HOLDER	1	
67	84110-12015	BEARING	1	1	97	84110-12092	ROLLER	1	2
68	84110-12056	FINAL PLANET CARRIER	1		98	84110-12093	SPRING	1	
69	84110-15000	SPRING (BLUE)	1		99	84110-12094	STEEL BALL	14	14
70	84110-12084	LOCK WASHER	1		100				
71	84110-12085	ADJUSTING RING	1		101	84110-12010	CLUTCH CASE COMPLETE	1	
72	84110-12086	CIRCLIP	1	1	102	84110-12074	SPINDLE BEARING	1	
73	84110-12087	BALL	3	3	103	84110-12075	CLUTCH CASE	1	
74	84110-12057	PUSH ROD	1		104	84110-12076	SPRING RING	1	
75	84110-12058	NAME PLATE	1		105				
76	84110-12059	PLANET WHEEL	3		106	84110-12077	PUSH ROD	1	
77	84110-12060	GASKET	1		107				
78	84110-12061	LIFT VALVE ASSY	1		108	84110-12078	SHIMS	1	
79	84110-12062	VALVE BUSH	1		109				
80	84110-12063	GASKET	1		110	84110-12079	CLUTCH COMPLETE	1	
81	84110-12064	GASKET	1		111	84110-12080	PLANET CARRIER SA	1	
82	84110-12065	RING	1		112				
83	84110-12066	SELF ADHESIVE TAPE	1		113	84110-12081	CAGED NEEDLE ASSY	3	3
84	84110-12088	SPACER	1		114	84110-12082	PLANET WHEEL	3	
85	84110-12067	LOCK WASHER	2		115				
86	84110-12068	SCREW M5 X 40	2		116				
87	84110-12069	SHUTTLE VALVE	1		117	84110-12083	ROTOR PINION	1	
88	84110-12070	CIRCLIP	2		118				
89	84110-12071	CAP	2		120	84110-12084	LABEL REVERSE VALVE	1	
90	84110-12072	SPRING	1		121	84110-12045	BIT HOLDER SA	1	

# Fault Diagnosis

Symptom	Possible Cause	Remedy	Page Ref
Tool reverses before Insert is placed	Worn thrust bearing or thrust washers	Replace	10
	Dirty insert threads	Change batch of inserts	
	Worn drive screw	Replace	10
	Lack of lubrication on drive screw (Standard Nutserts only)	Lubricate drive screw properly	
	Thrust spring not fitted	Fit thrust spring	10
	Clutch torque setting too low	Adjust to correct setting	15
	Insufficient pressure/volume of air	Check air supply/fittings	8
Tool runs slowly	Insufficient air pressure	Adjust air pressure at base of handle 5 -6.3 bar maximum.	8
	Incorrect bore of hose	Ensure bore of hose is 6.4mm minimum	8
	Insufficient air volume	Ensure there is no restriction in the air supply or connections	8
	Tool not properly lubricated internally	Lubricate as per instructions	12
	Tool fails to start	Tool not properly lubricated	Lubricate then depress trigger several times
Restricted air pressure/volume		Ensure there is no restriction in the air supply	8
Tool runs permanently in reverse mode	Push rod too long	Replace with one of correct length	19
	Insufficient air supply	Adjust air pressure/volume	5
Tool runs permanently in forward mode	Push rods/needle roller missing	Replace where necessary	19
	Push rod too short	Replace	19
Inserts not pulling up	Torque setting too low	Adjust to correct setting	15
	Insufficient air pressure/volume	Adjust air pressure/volume	8
	Inserts out of grip	Select correct insert	
	Lack of lubrication on insert	Change batch of inserts	
	Lack of lubrication on drive screw (Standard Nutserts only)	Lubricate drive screw correctly	
	Insert thread restricted	Change Inserts	
	Drive screw thread worn	Replace drive screw	10
	Incorrect insert/drive screw	Replace with correct insert/drive screw	10

continued overleaf

Other symptoms or failures should be reported to your local Avdel authorised distributor or repair centre.

# Fault Diagnosis

Symptom	Possible Cause	Remedy	Page Ref
Standard Nutserts centres falling out	Dirty Nutserts	Clean Nutserts	
	Clutch torque setting too low	Adjust to correct setting	15
	Application thickness below minimum	Change to correct Insert recommended grip	
	Oversize hole in application	Correct hole size in application	
Worn drive screws	Clutch torque setting too high	Adjust to correct setting	15
	Drive screw not lubricated	Lubricate drive screw regularly when using Standard Nutserts	
	Inserts not lubricated	Change batch of inserts	
	Tool not held correctly	Ensure tool is held square to application	
	Incorrect insert/drive screw threads	Replace with correct insert/drive screw	10
	Restricted insert threads	Change batch of inserts	

Other symptoms or failures should be reported to your local Avdel authorised distributor or repair centre.

# Notes

# Declaration of Conformity

We, Avdel UK Limited, Watchmead Industrial Estate, Welwyn Garden City, Herts, AL7 1LY  
declare under our sole responsibility that the product:

**Model 74110**

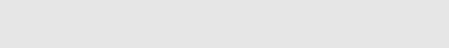
Serial No. 

to which this declaration relates is in conformity with the following standards:

EN ISO 12100 - parts 1 & 2

BS EN ISO 8662 - part 6

BS EN ISO 3744

ISO EN 792 part 13 - 2000

BS EN ISO 11202

BS EN 982

BS EN 983

following the provisions of the Machine Directive 89/392/EC

(as amended by Directive 91/368/EC, 93/44/EC as superceded by 98/37/EC and 93/68/EC)

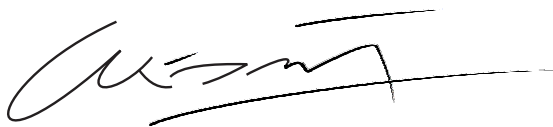

A. Seewraj - Product Engineering Manager - Automation Tools

Date of issue



**This box contains a power tool which is in conformity with  
Machines Directive 89/392/EC. The 'Declaration of  
Conformity' is contained within.**



An Acument™ Global Technologies Company

**AUSTRALIA**

**Acument Australia Pty Ltd.**

891 Wellington Road  
Rowville, Victoria 3178  
Tel: +61 3 9765 6400  
Fax: +61 3 9765 6445  
Email: info@acument.com.au

**CANADA**

**Avdel Canada, a Division of Acument  
Canada Limited**

87 Disco Road  
Rexdale  
Ontario M9W 1M3  
Tel: +1 416 679 0622  
Fax: +1 416 679 0678  
Email: infoAvdel-Canada@acument.com

**CHINA**

**Acument China Ltd.**

RM 1708, 17/F., Nanyang Plaza,  
57 Hung To Rd., Kwun Tong  
Hong Kong  
Tel: +852 2950 0631  
Fax: +852 2950 0022  
Email: info@acument.com.hk

**FRANCE**

**Avdel France S.A.S.**

33 bis, rue des Ardennes  
BP4  
75921 Paris Cedex 19  
Tel: +33 (0) 1 4040 8000  
Fax: +33 (0) 1 4208 2450  
Email: AvdelFrance@acument.com

**GERMANY**

**Avdel Deutschland GmbH**

Klusriede 24  
30851 Langenhagen  
Tel: +49 (0) 511 7288 0  
Fax: +49 (0) 511 7288 133  
Email: AvdelDeutschland@acument.com

**ITALY**

**Avdel Italia S.r.l.**

Viale Lombardia 51/53  
20047 Brugherio (MI)  
Tel: +39 039 289911  
Fax: +39 039 2873079  
Email: vendite@acument.com

**JAPAN**

**Acument Japan Kabushiki Kaisha**

Center Minami SKY,  
3-1 Chigasaki-Chuo, Tsuzuki-ku,  
Yokohama-city, Kanagawa Prefecture  
Japan 224-0032  
Tel: +81 45 947 1200  
Fax: +81 45 947 1205  
Email: info@acument.com.jp

**SINGAPORE**

**Acument Asia Pacific (Pte) Ltd.**

#05-03/06 Techlink  
31 Kaki Bukit Road 3  
Singapore, 417818  
Tel: +65 6840 7431  
Fax: +65 6840 7409  
Email: Tlim@acument.com

**SOUTH KOREA**

**Acument Korea Ltd.**

212-4, Suyang-Ri,  
Silchon-Eup, Kwangju-City,  
Kyunggi-Do, Korea, 464-874  
Tel: +82 31 798 6340  
Fax: +82 31 798 6342  
Email: info@acumentkorea.com

**SPAIN**

**Avdel Spain S.A.**

C/ Puerto de la Morcuera, 14  
Poligono Industrial Prado Overa  
Ctra. de Toledo, km 7,8  
28919 Leganés (Madrid)  
Tel: +34 (0) 91 3416767  
Fax: +34 (0) 91 3416740  
Email: ventas@acument.com

**UNITED KINGDOM**

**Avdel UK Limited**

Pacific House  
2 Swiftfields  
Watchmead Industrial Estate  
Welwyn Garden City  
Hertfordshire  
AL7 1LY  
Tel: +44 (0) 1707 292000  
Fax: +44 (0) 1707 292199  
Email: enquiries@acument.com

**USA**

**Avdel USA LLC**

614 NC Highway 200 South  
Stanfield,  
North Carolina 28163  
Tel: +1 704 888-7100  
Fax: +1 704 888-0258  
Email: infoAvdel-USA@acument.com

© Avdel UK Limited 2007

Manual No.	Issue	Change Note No.	Date
07900-00794	AA	03/046	
	AB	07/176	

Avdel®, Avdel® SR, Hexsert®, Nutsert®, Supersert®, are trademarks of Avdel UK Limited.