

Avlug® 1107



For installation information please refer to the tooling overview and manuals on our website www.avdel-global.com.
 Pour les conditions de pose, merci de vous référer à la description de l'outil et aux manuels disponibles sur notre site Web.
 Angaben zur Verarbeitung entnehmen Sie bitte der Geräteübersicht und den Betriebsanleitungen auf unserer Website.
 Per informazioni sull'installazione preghiamo consultare i manuali e la panoramica degli attrezzi sul nostro sito web.
 Para ver información sobre máquinas de colocación, consulte nuestra página web, apartados visión general de máquinas y manuales.

English	Français	Deutsch	Italiano	Español
Dome head	Tête plate	Flachrundkopf	Testa tonda	Cabeza alomada
Brass*	Laiton*	Kupfer-Zink Legierung*	Ottone*	Latón*
Tin plated**	Etamé**	verzinkt**	Stagnato**	Estañado**

*: BS EN 12166 CW 508L DIN 17660 CuZn37

** : Avdel recommends tin plated parts are installed within nine months from the date they were produced / Avdel conseille d'utiliser les pièces en laiton étamé sous un délai de 9 mois après la date de production / Avdel empfiehlt, verzinkte Niete innerhalb 9 Monaten nach Produktionsdatum zu verarbeiten / Avdel raccomanda di utilizzare i prodotti stagnati entro nove mesi a decorrere dalla data di fabbricazione / Avdel recomienda utilizar sus piezas estañadas antes de nueve meses desde la fecha de su fabricación.

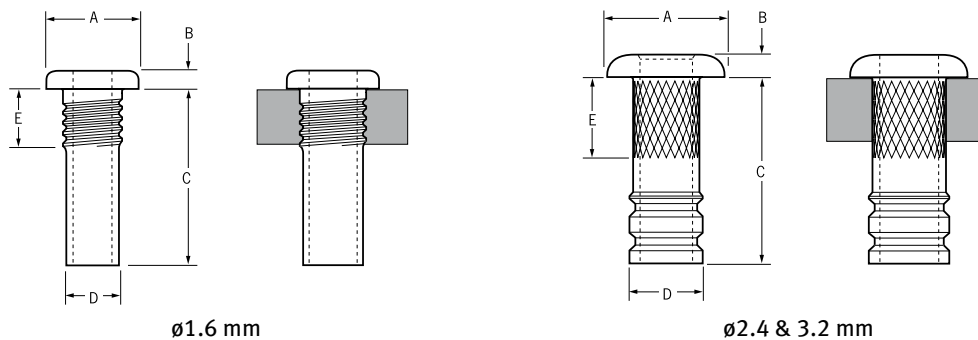

Ø1.6 mm

Ø2.4 & 3.2 mm

Ø	🌀		A	B	C	D	E	No. of grooves / cannelures / Rillen / rigature / aros	Fasteners per pod/ Nombre de rivets par chargeur / Niete pro Magazin/ Rivetti per caricatore / Uds./carga	Part No/ref
	nom.	min.								
1.6 (1/16")	1.80	1.93	2.80	0.61	4.11	1.79	2.04	4	62	01107-00205
					6.51					
2.4 (3/32")	2.62	2.74	4.15	0.94	8.36	2.60	3.43	2	33	01107-00310
					9.96			3	28	01107-00312
3.2 (1/8")	3.38	3.51	5.52	1.15	9.96	3.36	3.43	3	26	01107-00412

all dimensions in mm / en millimètres / alle Maße in mm / in millimetri / en milímetros

1) typical values / valeurs moyennes / typische Werte / Valori tipici / resistencias máximas recomendadas



An Acument™ Global Technologies Company

www.avdel-global.com

© 2007 Acument Intellectual Properties, LLC

Avlug® is a trademark of Avdel UK Limited

04b.2007

Data shown is subject to change without prior notice as a result of continuous product development and improvement policy.
 Your local Avdel representative is at your disposal should you need to confirm latest information.